

# BG-ADAMO-4K

**4K UHD AUTO TRACKING HDMI 2.0/12G-SDI/USB 2.0/USB 3.0 Live Streaming  
PTZ Camera with Tally Lights**

## User Manual







## Table of Contents

|  |    |
|--|----|
| Statement                                    | 4  |
| Safety Precaution                            | 4  |
| Introduction                                 | 5  |
| Features                                     | 5  |
| Packing List                                 | 6  |
| Specifications                               | 6  |
| Installation and Handling Caution            | 8  |
| Camera Interface                             | 8  |
| RS-232 Interface                             | 9  |
| VISCA Networking                             | 10 |
| Mounting                                     | 10 |
| Wall Mounting                                | 10 |
| Ceiling Mounting                             | 11 |
| Operating Instructions                       | 12 |
| Power on and Self-check                      | 12 |
| Remote                                       | 13 |
| Remote Buttons Introduction                  | 13 |
| Network Connection                           | 17 |
| Initial Web Client Login                     | 19 |
| Preview                                      | 20 |
| SD Card Recording                            | 21 |
| Auto-Tracking Configuration                  | 21 |
| Zone Tracking Setup                          | 22 |
| General Configuration                        | 23 |
| Audio Configure                              | 24 |
| Video Encode and Streaming                   | 24 |
| Video Encode                                 | 24 |
| Video Stream Capture                         | 25 |
| Live Stream Publish                          | 26 |
| Multicast/Unicast                            | 27 |
| Video Parameters                             | 28 |
| Video OSD and OSD Font                       | 32 |
| Video Out                                    | 33 |
| Network Configure                            | 33 |
| Network Port                                 | 33 |
| Ethernet                                     | 34 |
| DNS  | 34 |
| GB28181, SRT, and RTSP Authentication        | 35 |
| System Configure                             | 36 |
| System Attribute, System Time, & System User | 36 |
| Auto Reboot                                  | 37 |
| Operation System                             | 38 |



|                                       |    |
|---------------------------------------|----|
| Update, Default, & Reboot             | 38 |
| Serial Port Communication and Control | 39 |
| VISCA Protocol List                   | 39 |
| VISCA Protocol Return Command         | 39 |
| VISCA Protocol Control Commands       | 39 |
| VISCA Protocol Inquiry Commands       | 43 |
| Pelco-D Protocol Command List         | 46 |
| Pelco-P Protocol Command List         | 47 |
| Maintenance and Troubleshooting       | 48 |
| Tech Support                          | 49 |
| Warranty                              | 50 |
| Mission Statement                     | 51 |
| Copyright                             | 52 |

## Statement

---

Please read these instructions carefully before connecting, operating, or configuring this product. Please save this manual for future reference.

## Safety Precaution

---

- To prevent damaging this product, avoid heavy pressure, strong vibration, or immersion during transportation, storage, and installation.
- The housing of this product is made of organic materials. Do not expose to any liquid, gas, or solids which may corrode the shell.
- Do not expose the product to rain or moisture.
- To prevent the risk of electric shock, do not open the case. Installation and maintenance should only be carried out by qualified technicians.
- Do not use the product beyond the specified temperature, humidity, or power supply specifications.
- Wipe the lens with a soft, dry cloth when cleaning. Wipe it gently with a mild detergent if needed. Do not use strong or corrosive detergents to avoid scratching the lens and affecting the image.
- This product does not contain parts that can be maintained or repaired by users. Damage caused by dismantling the product without authorization from BZBGear is not covered under the warranty policy.
- Installation and use of this product must strictly comply with local electrical safety standards. The power supply of the product is  $\pm 12V$ , and the max electrical current is 2A.
- Electromagnetic fields at specific frequencies may affect the video image.



## Introduction

---

The BZBGear BG-ADAMO-4K is an ultra-high-definition PTZ camera that delivers 4K resolution video at 60fps. Available with either the 12x optical zoom lens with an 80.4° wide-angle, or the 25x optical zoom lens with a 59° wide-angle. Featuring USB 2.0, USB 3.0, LAN, HDMI, and 12G-SDI video connections. The 3D noise reduction technology combined with the low-noise CMOS sensor ensures impeccable image clarity. The innovative auto-tracking software is intuitively designed for ease-of-use with two modes (presenter and zone) for exceptional results.

## Features

---

- **4K UHD Resolution:** The SONY CMOS sensor captures images in resolutions up to 3840x1260 with a frame rate of up to 60fps.
- **Interfaces / Multiple Simultaneous Streaming Outputs:** With a variety of outputs such as HDMI 2.0, 12G-SDI, USB3.0, USB 2.0, and LAN, the ADAMO can simultaneously broadcast multiple streams to multiple outputs.
- **Optical Zoom Lens:** The ADAMO features either a 12X optical zoom 80.4° wide-angle lens or 25X optical zoom 59° wide-angle lens.
- **Multiple Audio/Video Compression Standards:** H.264/H.265 video compression is supported by the LAN interface, USB 3.0 supports YUY2, and USB 2.0 supports MJPG, H.264, YUY2, NV12, H.265. USB 3.0 supports YUY2. The A-IN supports AAC audio compression coding.
- **Advanced Auto Focusing Algorithm:** The lens promptly snaps into focus with dependable accuracy and stability.
- **Low Noise and High SNR:** A high SNR (Signal to Noise Ratio) image is achieved using low noise CMOS sensors. The sophisticated 2D and 3D noise reduction technology further reduces the noise while ensuring high image clarity, even in low light.
- **Supported Network Protocol:** ONVIF, GB/T28181, RTSP, RTMP.
- **Control Options:** RS232, RS485, LAN, or IR remote control. Protocols include VISCA, PELCO-P/D, ONVIF, and VISCA over IP.
- **Multiple Presets:** Configure up to 255 presents using the Web GUI, or 10 presents via the IR remote control.
- **Two Mode Auto-Tracking Software:** Presenter mode continuously tracks keeping the subject perfectly framed. Zone mode holds the frame in predetermined zones. The camera tracks and moves only when the subject has left one zone and entered the next, then holds the frame in the new zone.



## Packing List

- 1 x BG-ADAMO-4K
- 1 x IR Remote Control
- 1 x 12V/1.5A Power Supply
- 1 x RS232 Control Cable
- 1 x User Manual

## Specifications

| Camera Parameters    |   |   |
|----------------------|---|---|
| Optical Zoom         | 12X<br>f=3.85 mm~ 43.06 mm ±5%  | 25X<br>f=6.91 mm~ 214.64 mm ±5%                                     |
| View Angle           | Horizontal: 7.59° (N) ~ 80.4° (W)<br>Vertical: 4.6° (N) ~ 50.0° (W)   | Horizontal: 1.98° (N) ~ 59° (W)<br>Vertical: 1.12° (N) ~ 34.14° (W) |
| Iris Value           | F1.8(Wide) ~ F3.56(Tele) ±5%  | F1.35(Wide) ~ F4.6(Tele) ±5%  |
| Sensor               | 1/2.5 inch SONY CMOS sensor   | 1/1.8 inch SONY CMOS sensor   |
| Effective Pixels     | 8.51M megapixel 16:9  |   |
| Video Format         | HDMI :<br>3840*2160P60/50/30/25/59.94/29.97;1080P60/50/ 30/25/59.94/29.97;1080i60/50/59.94;<br>720P60/50/59.94<br>SDI :<br>3840*2160P60/50/30/25/59.94/29.97;1080P60/50/ 30/25/59.94/29.97;1080i60/50/59.94;<br>720P60/50/59.94<br>USB 2.0:<br>MJPG : 3840*2160/1920*1080/1280*720 /1024*768<br>/1024*576/800*600/720*576/720*480/704*576/640*480 /640*360 /352*288/320*240P30<br>H.264 : 3840*2160/1920*1080/1280*720 /1024*768<br>/1024*576/800*600/720*576/720*480/704*576/640*480 /640*360 /352*288/320*240P30<br>H.265 : 1920*1080/1280*720 /1024*768<br>/1024*576/800*600/720*576/720*480/704*576/640*480 /640*360 /352*288/320*240P30;<br>YUY2 : 800*448 /720*480P25; 640*360 /432*240P30<br>NV12 : 800*448P25; 640*480 /640*360 /432*240P30<br>USB 3.0:<br>YUY2 : 1920*1080 /1280*720P60/50/30/25; 960*540 /800*600P30; 720*576P50;<br>720*480P60;640*480P30; |   |
| Minimum Illumination | 0.5Lux (F1.8, AGC ON)   |   |
| DNR                  | 3D DNR  |   |
| White Balance        | Auto / Manual/ One Push/ Specified Temperature  |   |
| Focus                | Auto/Manual/One Push Focus  |   |
| Exposure Mode        | Auto/Manual/Shutter priority/Aperture priority/brightness priority  |   |
| Aperture             | F1.8 ~ F11 CLOSE  |   |
| Shutter Speed        | 1/25~1/10000  |   |
| BLC                  | ON/OFF  |   |
| Video Adjustment     | Brightness, Color, Saturation, Contrast, Sharpness, B/W mode, Gamma curve   |   |



|                               |  |
|-------------------------------|--|
| SNR                           | ≥50dB  |
| <b>Interface</b>              |  |
| Product Interfaces            | HDMI, 12G-SDI, LAN (supports PoE), USB 2.0, A-IN, USB 3.0, SD (FAT32), RS232-IN, RS232-OUT, RS422 (compatible with RS485), DC12V, Power Switch |
| Video Compression Format      | LAN Interface: H.264, H.265<br>USB 2.0 Interface: MJPG, H264, YUY2, NV12<br>USB 3.0 Interface: YUY2  |
| Audio Input Interface         | Stereo 3.5mm AUX   |
| Audio Output Interface        | HDMI, LAN, 12G-SDI, USB 2.0, USB 3.0   |
| Audio Compression Format      | AAC  |
| Network Interface             | 10M/100M/1000M adaptive Ethernet port, PoE power supply, audio and video output  |
| Network Protocols             | RTSP, RTMP, ONVIF, GB/T28181; VISCA IP control protocol  |
| Control Interface             | RS232-IN, RS232-OUT, RS422 compatible with RS485, LAN  |
| Serial Communication Protocol | VISCA/Pelco-D/Pelco-P;<br>Baud Rate: 115200/38400/9600/4800/2400   |
| USB Communication Protocol    | UVC (Video)  |
| Power Interface               | HEC3800 outlet (DC12V), PoE  |
| Supply Adapter                | AC110V~AC220V to DC12V/2.5A  |
| Input Voltage                 | DC12V±10%  |
| Input Current                 | <1.5A  |
| Power Consumption             | <12W   |
| <b>PTZ Parameters</b>         |  |
| Pan Rotation                  | -170°~+170°  |
| Tilt Rotation                 | -30°~90°   |
| Pan Control Speed             | 0.1°/s ~ 100°/s  |
| Tilt Control Speed            | 0.1°/s ~ 70°/s   |
| Preset Speed                  | Pan: 78.8°/s, Tilt: 31.7°/s  |
| Preset Number                 | 255 presets via Web GUI (10 presets using remote control)  |
| <b>Other Parameters</b>       |  |
| Stored Temperature            | 14°F ~ 140°F / -10°C ~ +60°C   |
| Storage Humidity              | 20%~95%  |
| Working Temperature           | 14°F ~ 122°F / -10°C ~ +50°C   |
| Working Humidity              | 20%~80%  |
| Dimension (L x W x H)         | 8.7" x 5.9" x 7" [220mm x 150.2mm x 177.5mm]   |
| Weight                        | ~4 Lbs [~1.8kg]  |
| Application                   | Indoor   |



## Installation and Handling Caution

- Do not manually rotate the camera head as it could cause mechanical failure.
- Place the camera on a stable table or horizontal surface. Installing on a slanted surface will result in a slanted image.
- Do not place obstacles within the camera's rotation circumference.
- For proper operation and synchronization, do not power the camera on until the cable installation has been completed.

## Camera Interface

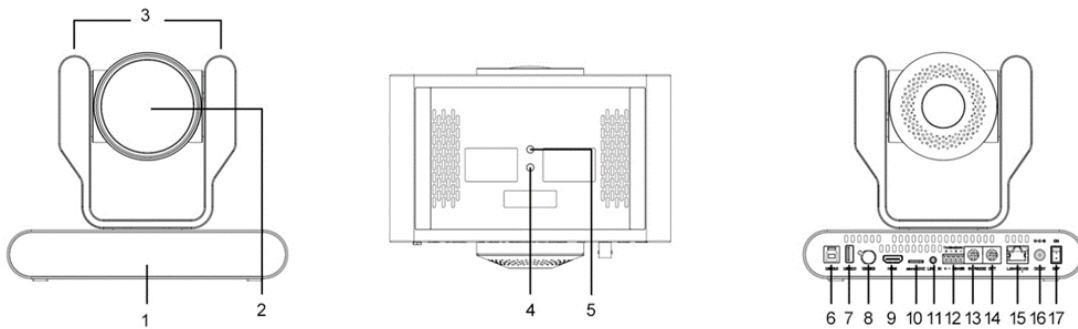

|                                |                           |                                   |
|--------------------------------|---------------------------|-----------------------------------|
| 1. Remote-control IR Indicator | 7. USB 2.0                | 13. RS232 Control Interface (In)  |
| 2. Camera Lens                 | 8. 12G-SDI Output         | 14. RS232 Control Interface (Out) |
| 3. Tally Lights                | 9. HDMI Output            | 15. LAN/PoE                       |
| 4. Mounting Hole               | 10. Micro SD slot         | 16. DC12V Power Input             |
| 5. Screw Hole for Tripod       | 11. Audio Input           | 17. Power Switch                  |
| 6. USB 3.0                     | 12. RS422/RS485 Interface |                                   |

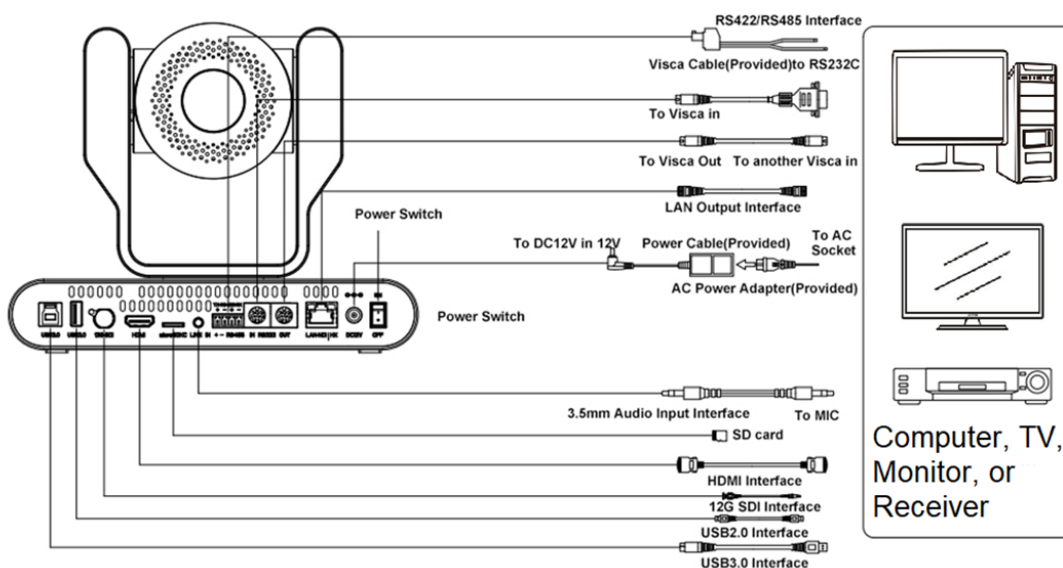





## RS-232 INTERFACE

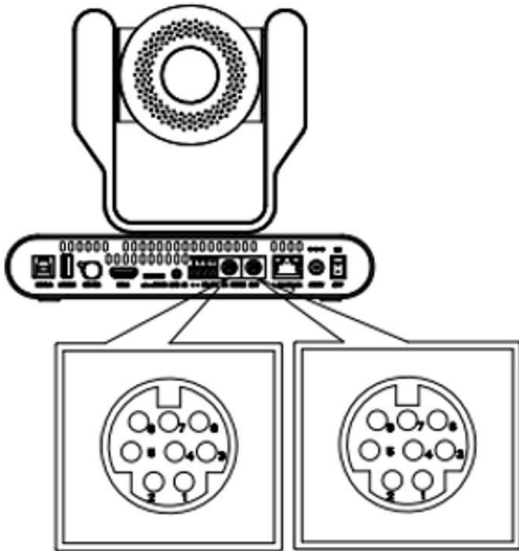
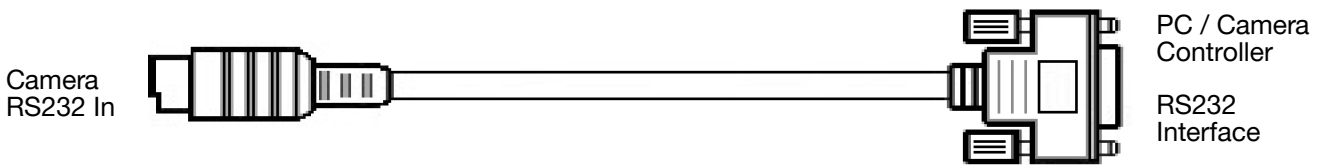

### Connection to PC or Camera Controller

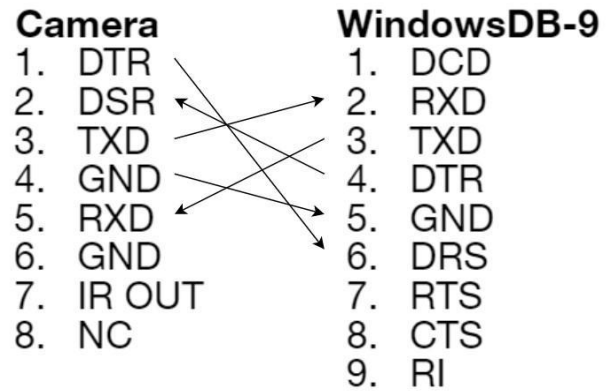

### RS-232 Mini-DIN 8-pin Port Definition

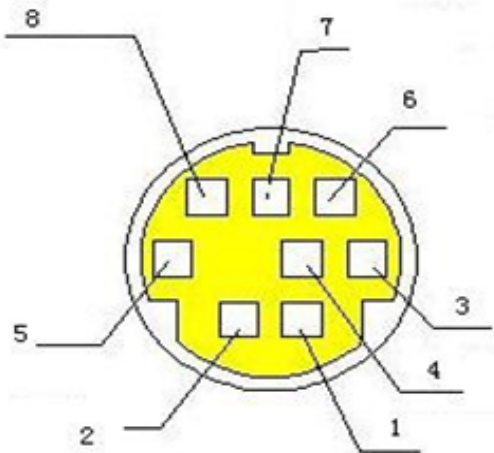

| NO. | Port   | Definition          |
|-----|--------|---------------------|
| 1   | DTR    | Data Terminal Ready |
| 2   | DSR    | Data Set Ready      |
| 3   | TXD    | Transmit Data       |
| 4   | GND    | Signal Ground       |
| 5   | RXD    | Receive Data        |
| 6   | GND    | Signal Ground       |
| 7   | IR OUT | IR Commander Signal |
| 8   | NC     | No Connection       |



### RS-232 (BD9) Port Connections

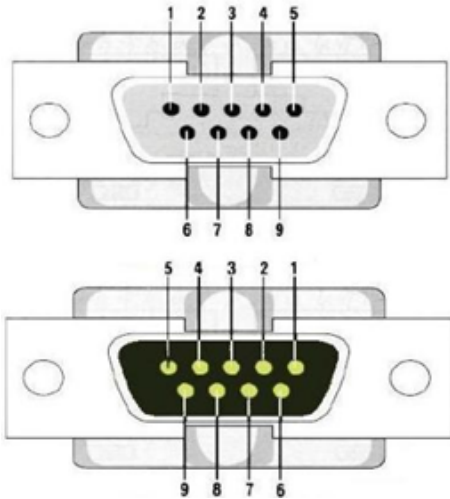

| NO. | Port | Definition          |
|-----|------|---------------------|
| 1   | DCD  | Definition          |
| 2   | RXD  | Data Carrier Detect |
| 3   | TXD  | Receive Data        |
| 4   | DTR  | Transmit Data       |
| 5   | GND  | Data Terminal Ready |
| 6   | DSR  | System Ground       |
| 7   | RTS  | Data Set Ready      |
| 8   | CTS  | Request to Send     |

## VISCA Networking

### Camera cascade connection

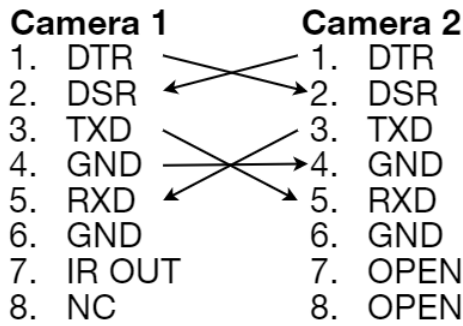

## Mounting

Note: Ceiling or wall mounting brackets should be mounted to a wooden or concrete wall. Mounting to plasterboard is not recommended for safety reasons.

## Wall Mounting

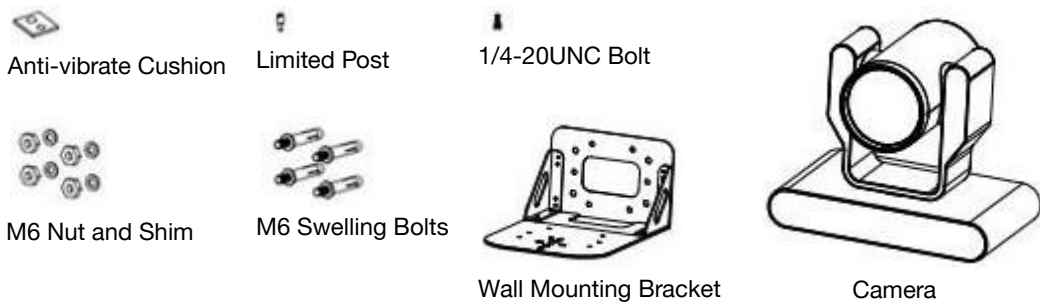

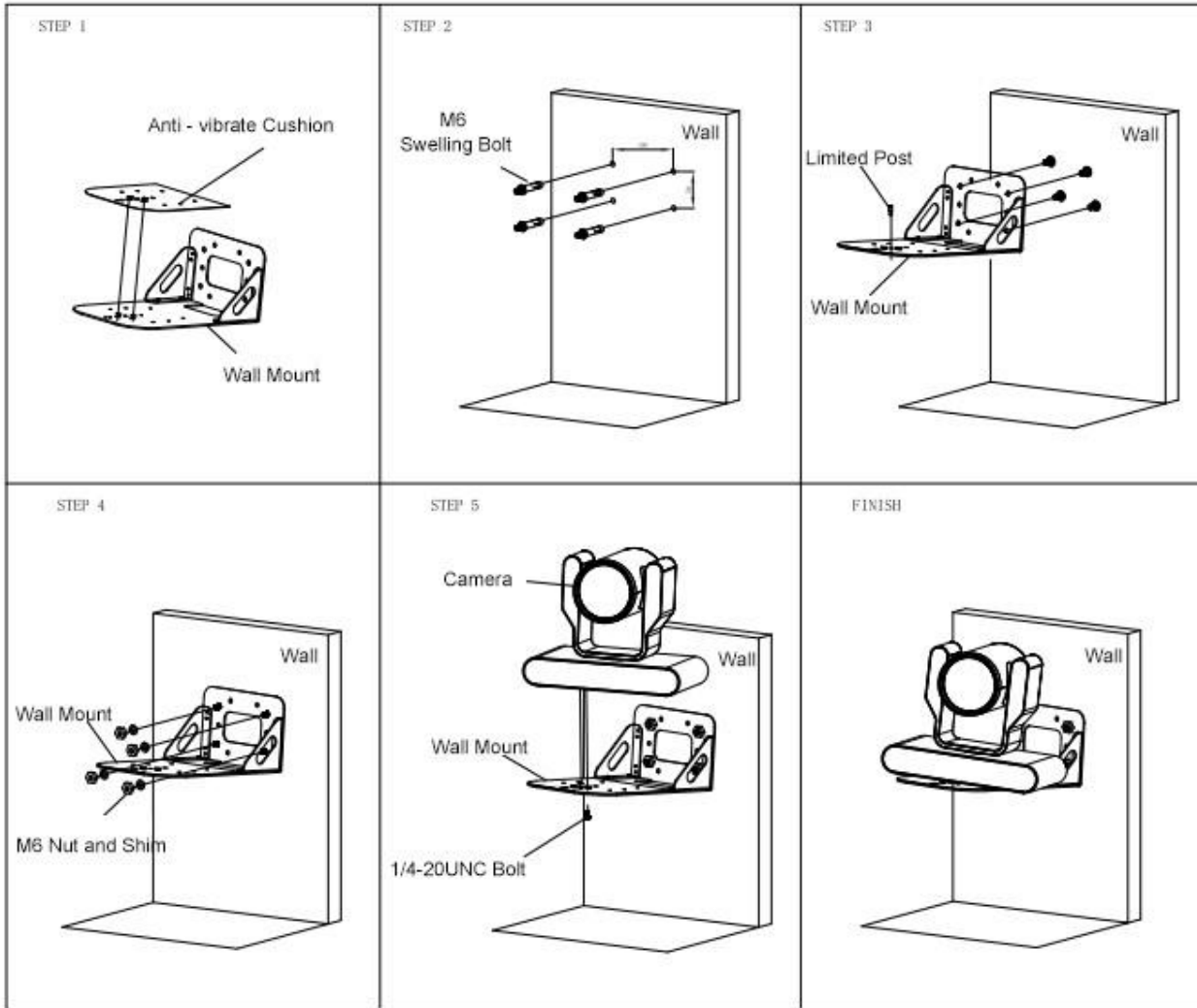

## Ceiling Mounting

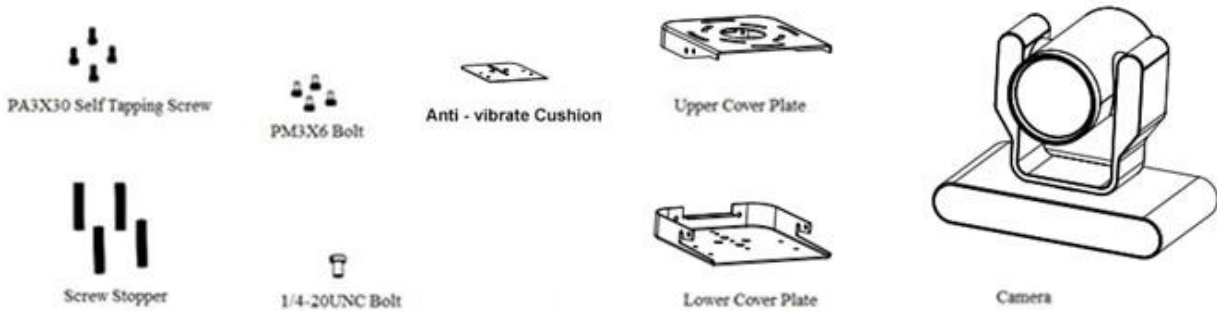

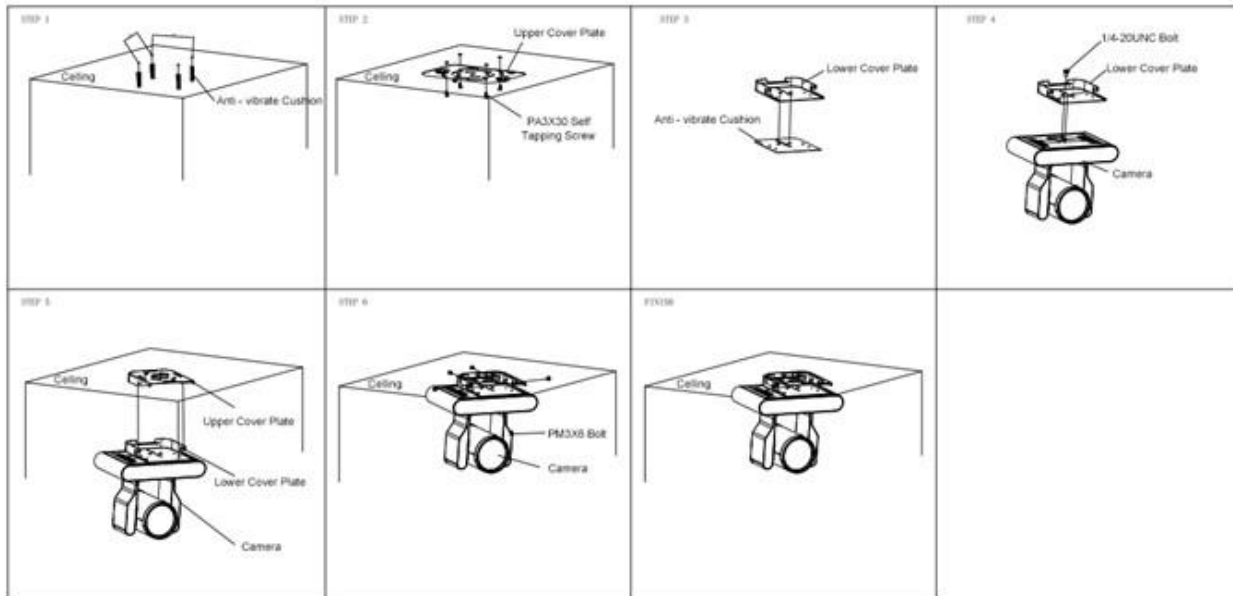

## Operating Instructions

### POWER ON AND SELF-CHECK

1. Power-on: Connect the DC12V power adaptor to the power supply socket on the back of the camera. or connect to a PoE enabled network switch using a category cable.
2. Camera Self-check: The remote-control IR indicator and tally lights will flash when powered on. The camera will pan-tilt to the lowest left position, then return to the HOME position (both the horizontal and vertical positions are in the middle). The lens/zoom will move through its complete range. Once the remote-control IR indicator and tally lights stop flashing, the self-check has been completed.

#### Notes:

1. After the power-on and self-check, the camera will automatically return to the preset 0 position.
2. The factory default address for the IR remote-control is #1.



## REMOTE

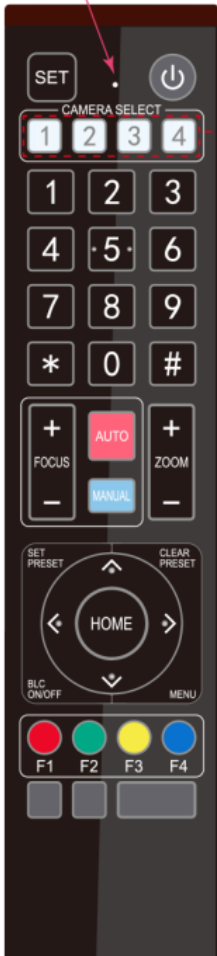

### One-to-One Code Matching:

Out of the box the remote is automatically paired with the camera. Should the camera need to be re-pair with the remote, perform the steps below.

1. Press the "set" and " \* " keys combined for 3 seconds. The LED indicator will start flashing.
2. The camera will receive the signal and power on if not already on.
3. The LED indicator will turn off if the code matching is successful.

If the one-to-one code matching has failed, the LED indicator will flash for 20 seconds and turn off. The camera will stop code matching and go into sleep mode. Press any key to wake the camera up and reattempt code matching.

## REMOTE BUTTONS INTRODUCTION

In this manual, "press the button" means a click rather than a "press and hold". Special instructions will be given if pressing and holding the button for more than one second is required. When a button-combination is required, perform the actions in sequence. For example, **[\*]+[#]+[F1]** means press **["\*"]** first, then **["#"]** and press **["F1"]** last.

### 1. Camera Remote Control Address Setting



- [\*]+[#]+[F1]**: Camera Address No. 1
- [\*]+[#]+[F2]**: Camera Address No. 2
- [\*]+[#]+[F3]**: Camera Address No. 3
- [\*]+[#]+[F4]**: Camera Address No. 4



## 2. Camera Selection

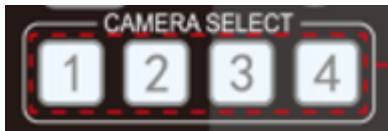

Select the camera's address to control it.

## 3. Pan/Tilt Control



**Up:** press ▲                      **Down:** press ▼  
**Left:** press ◀                      **Right:** press ▶  
 Return to middle position: press [HOME]

Press and hold the up, down, left, or right button to pan/tilt the camera. The camera will continue to move in the arrow direction until either the button is released or the camera has reached its full range of motion.

## 4. Focus Control and Zoom



**FOCUS + (near) :** Press to adjust the lens focus.

**FOCUS - (far) :** Press to adjust the lens focus.

**MANUAL :** Press to enter manual focus mode.

**AUTO :** Press to return to auto focus mode.

**ZOOM + :** Press to zoom in.

**ZOOM - :** Press to zoom out.

## 5. Set and Clear Presets



**Set Preset:** Press the [SET PRESET] button, then press the number buttons 0-9 to set the preset positions.

**Note:** 10 presets are available via remote control.

**Call Preset:** Press the 0-9 number buttons to call a preset position.

**Clear Preset:** Press the [CLEAR PRESET] button, then press the desired number button to clear its preset position.

**BLC ON/OFF:** Turn on/off the BLC.

**Menu:** Enter/Exit OSD menu or return to the previous menu.

**Note:** Pressing the [#] key three times in a row will clear all presets.





## 6. Auto Tracking Buttons



**F1:** Turn off auto tracking

**F2:** Turn on auto tracking

**F3:** Switch auto tracking modes

**F4:** Switch auto tracking to follow a different person

## 7. Key Combinations

**【#】+【#】+【#】:** Cancel all preset positions

**【\*】+【#】+【3】:** The menu is set to Chinese

**【\*】+【#】+【9】:** Toggle forward and backward

**【#】+【\*】+【Auto】:** Stop demo mode

**【#】+【#】+【0】:** Switch video format 4KP60

**【#】+【#】+【2】:** Switch video format 4KP30

**【#】+【#】+【4】:** Switch video format 1080P60

**【#】+【#】+【6】:** Switch video format 1080I60

**【#】+【#】+【8】:** Switch video format 1080P30

**【\*】+【#】+【6】:** Restore factory image defaults

**【\*】+【#】+【4】:** The menu is set to English

**【\*】+【#】+【Auto】:** Enter demo mode

**【\*】+【\*】+【7】:** Turn on green tally light

**【\*】+【\*】+【8】:** Turn on red tally light

**【\*】+【#】+【Manual】:** IP, username, password restore to default

**【#】+【#】+【1】:** Switch video format 4KP50

**【#】+【#】+【3】:** Switch video format 4KP25

**【#】+【#】+【5】:** Switch video format 1080P50

**【#】+【#】+【7】:** Switch video format 1080I50

**【#】+【#】+【9】:** Switch video format 1080P25

**【\*】+【\*】+【1】:** Enable DHCP

**【\*】+【\*】+【2】:** Disable DHCP

**【\*】+【\*】+【3】:** Display current IP address

**【\*】+【\*】+【4】:** Reboot camera

**【\*】+【\*】+【5】:** Start recording to SD card

**【\*】+【\*】+【6】:** Stop recording to SD card

**【\*】+【\*】+【9】:** Turn off tally light





## 8. Main Menu

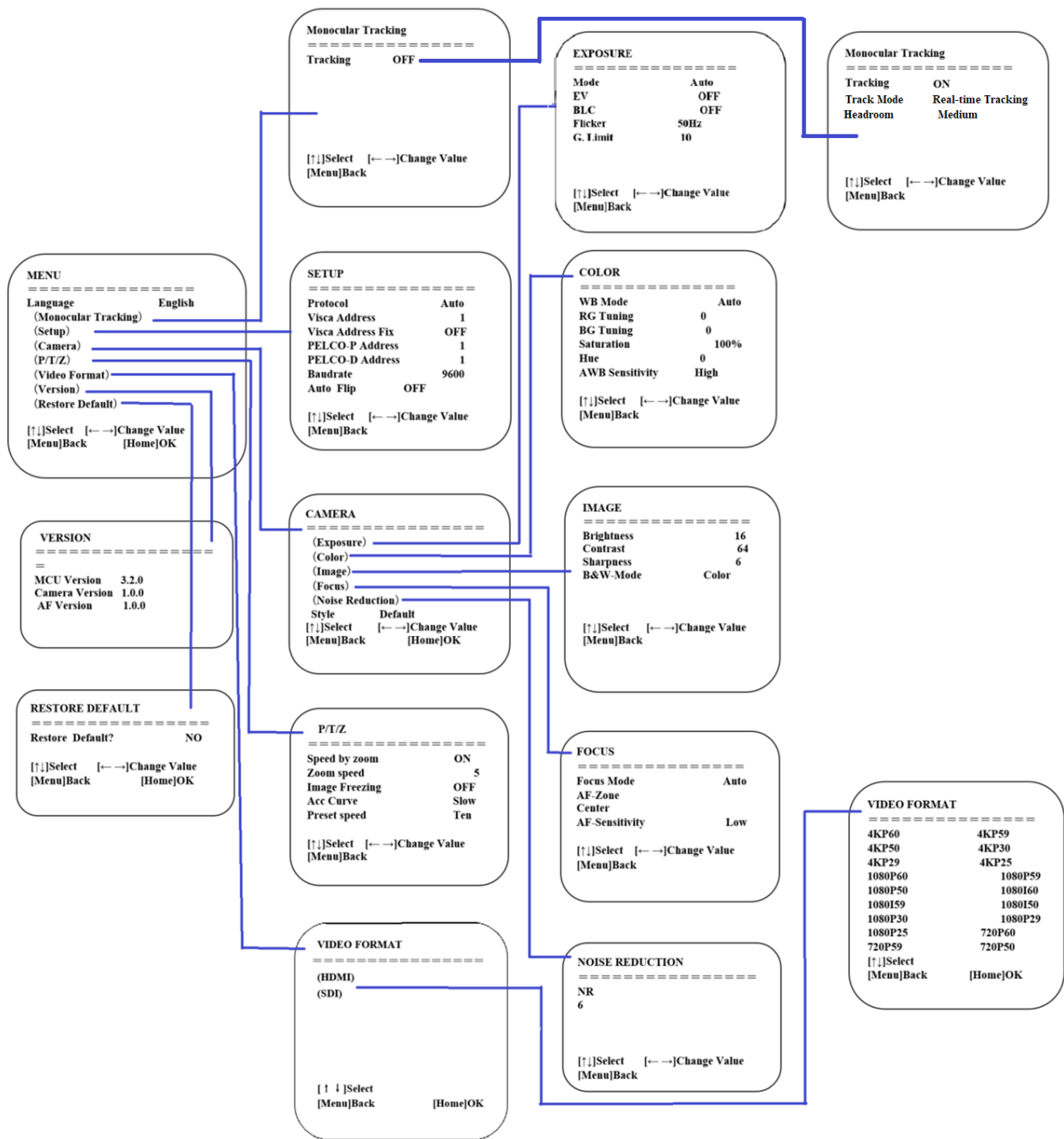





## Network Connection

### Connection Mode

- **Direct Connection:** Connect the camera directly to the computer using an ethernet cable.
- **Internet Connection:** Connect the camera and computer to a router or switch and access via the local area network (LAN).

**Note:** Ensure power and network connections are secured to prevent video issues caused by poor connection quality.

The computer must be on the same subnet as the camera to connect successfully. The device will not be accessible otherwise. The camera's default IP address is 192.168.5.163, therefore the computer must be connected to the 192.168.5.x subnet.

- To connect to the camera, open the Local Area Connection Properties on the computer.
- For Windows 10/11 users in the Start menu type/search for “**View Network Connections**”

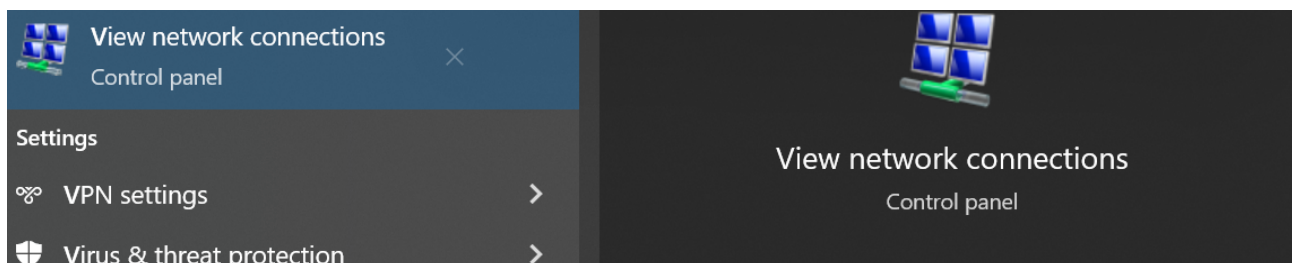

- Right-click on your connection and select “**Status**”.

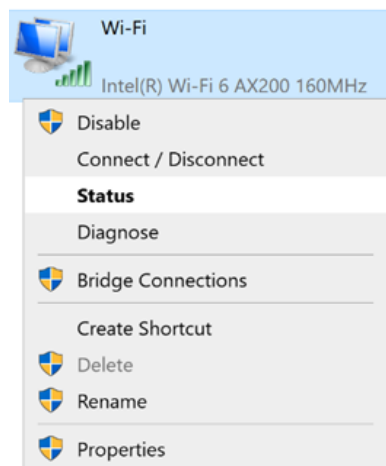

Then click “**Details...**” Take note of your current IPv4 Address and Default Gateway as you will need this information later. Close the “Details” and “Status” windows.



- Right-click on your adapter again (Wi-Fi or Ethernet) and select “**Properties**”.

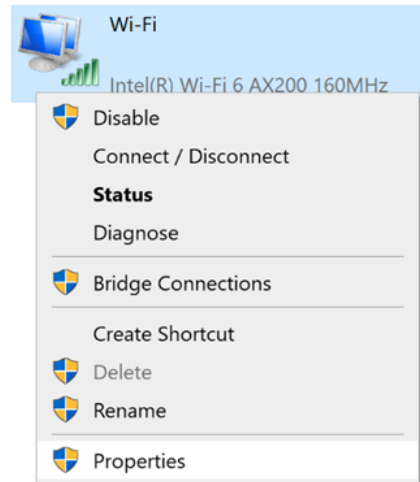

- Select “**Internet protocol version 4 (TCP/IPv4)**” as shown below and click “**Properties**”.

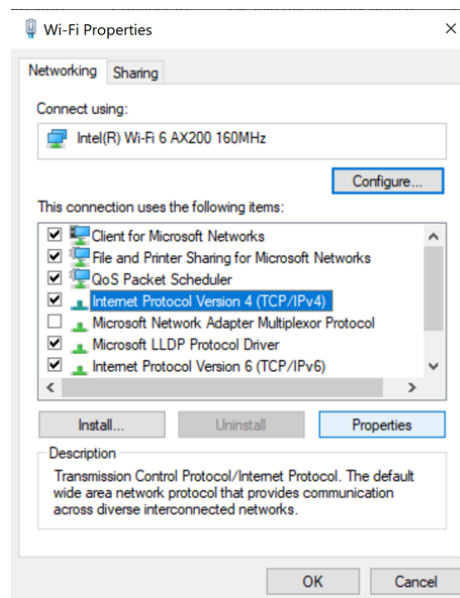

For the following steps refer to the diagram below.

- Click on the bubble for “**Use the following IP address**”
- In the IP address field, enter a non-conflicting IP address on the same subnet as the camera. If there is another device with the same IP address, you will not be able to connect. In the example below uses 192.168.5.200
- In the **Subnet mask** field enter 255.255.255.0
- In the **Default gateway** field type 192.168.5.1
- Leave the DNS fields blank.
- Click “**OK**” to apply the settings.

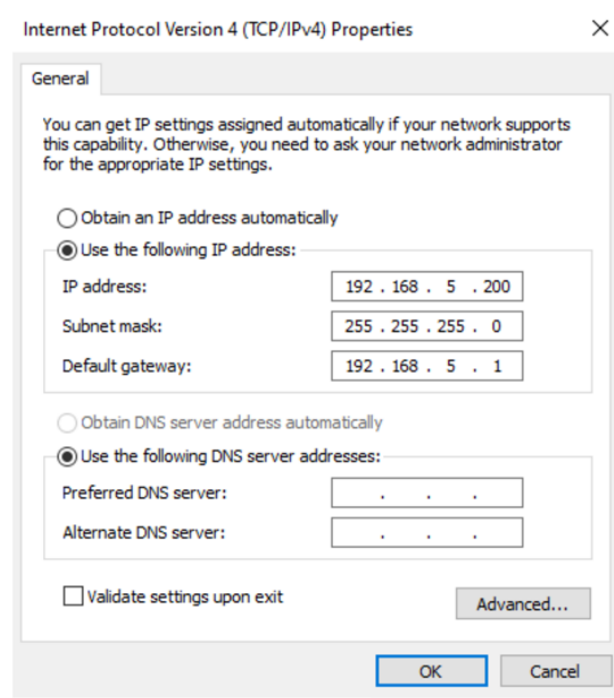

## Initial Web Client Login

- Enter 192.168.5.163 in the address bar of your internet browser and click “Enter”. Login as the administrator (Default Username/Password: admin). Users can preview and configure in the Web Client.
- When logged in as a normal user (Default Username/Password: user1 or user2), users can only preview with no options for configuration.

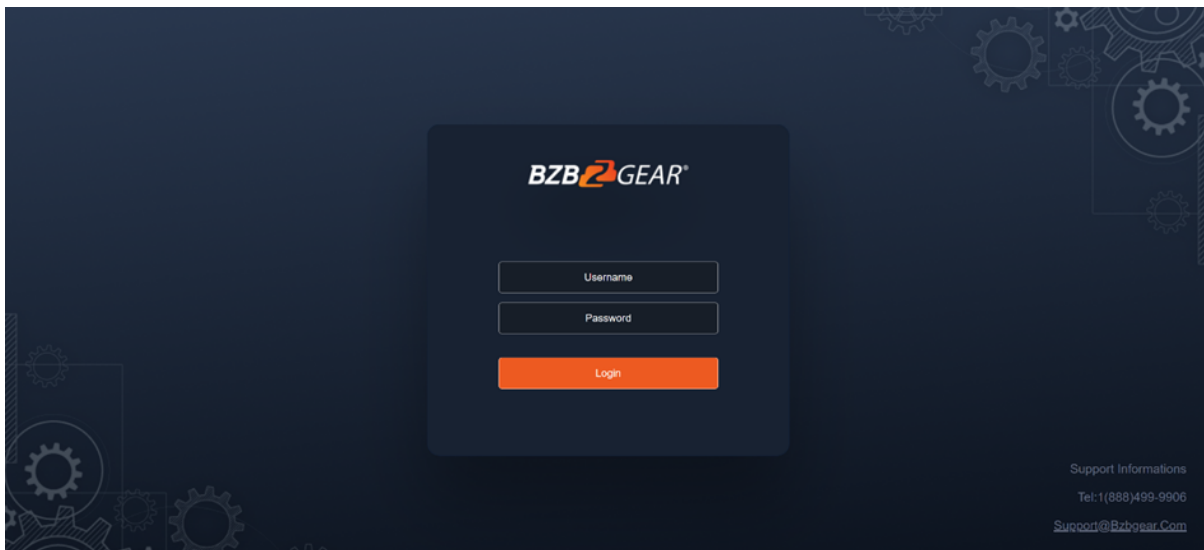



- Navigate to Configuration in the top left corner of the screen. Click “Ethernet” on the left-hand side.

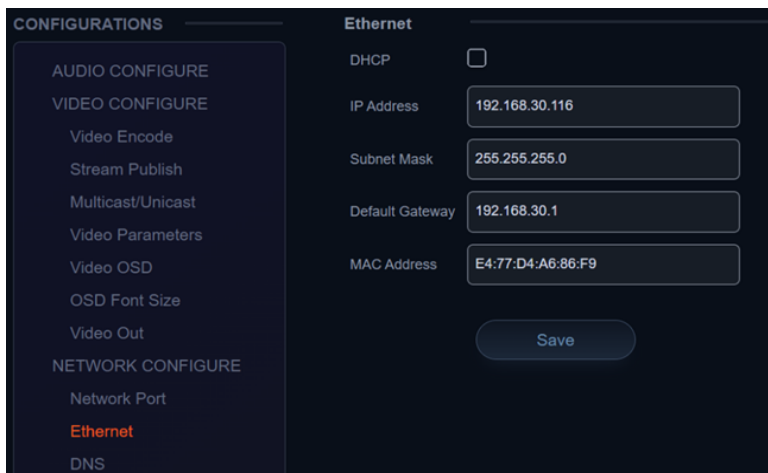

- Enter an unused IP address on your network.

**Note:** You should have your specific network information from the “Status” and “Details” pages of your internet connection noted above.

- In this example we will use 192.168.30.116
- Change the Subnet Mask to 255.255.255.0
- Default gateway of your network
- Click “Save”
- Reboot the Camera
- Once you have completed the camera network setup, repeat the steps on your computer to adjust the “Internet Protocol Version 4 (TCP/IPV4) Properties.” Select the bubbles to “Obtain an IP address automatically” and “Obtain DNS server address automatically.”

## Preview

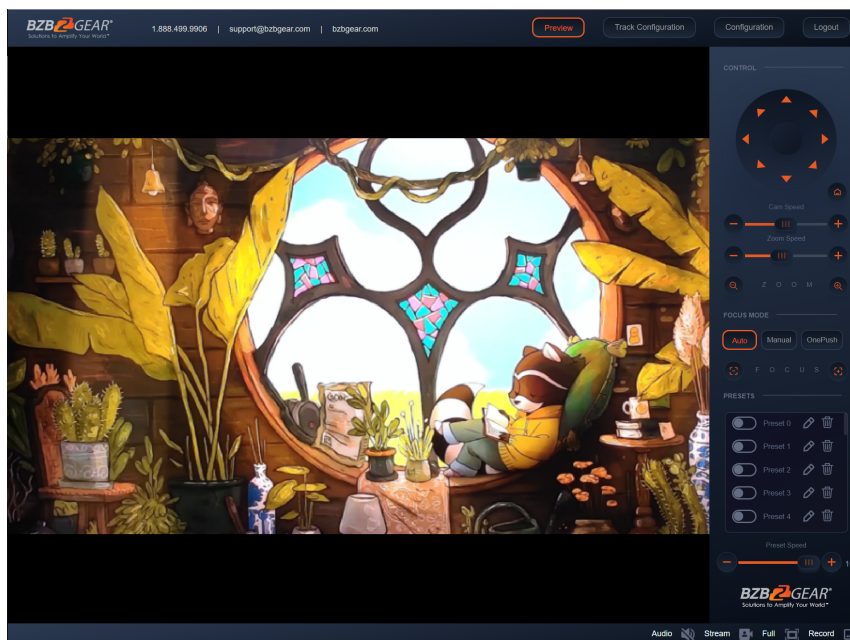

After successfully logging into the management interface, the web portal will enter the “Preview” tab. In Preview, users can control pan/tilt, zoom, focus, video capture, sound, focus, full screen preview, as well as set and recall preset positions and configure the “Home” preset position.



## SD Card Recording

- The recording option will appear in the bottom right corner of the “Preview Screen” after a compatible SD card is inserted into the camera.
  - The BG-ADAMO line of cameras currently only supports FAT32 format at this time. Before recording, ensure the SD card has been formatted properly.
- The BG-ADAMO is capable of using micro SD cards up to 1Tb when properly formatted.
  - **Note:** If your SD card does not allow you to format it to FAT32 a program such as “rufus-3.21.exe” may be required.
  - **Note:** FAT32 only allows for file sizes up to 4Gb so longer/higher resolution recordings may be broken up into several files.
- Recording parameters are changed by editing the Video Encode “Main Stream” settings.
- Synchronize the camera time before recording as file names will be generated based on system time.
- **WARNING!** Be careful when inserting a Micro SD card into the unit as there is an air gap above the SD socket and it may be possible to push a SD card into the housing if not properly inserted.

## Auto-Tracking Configuration

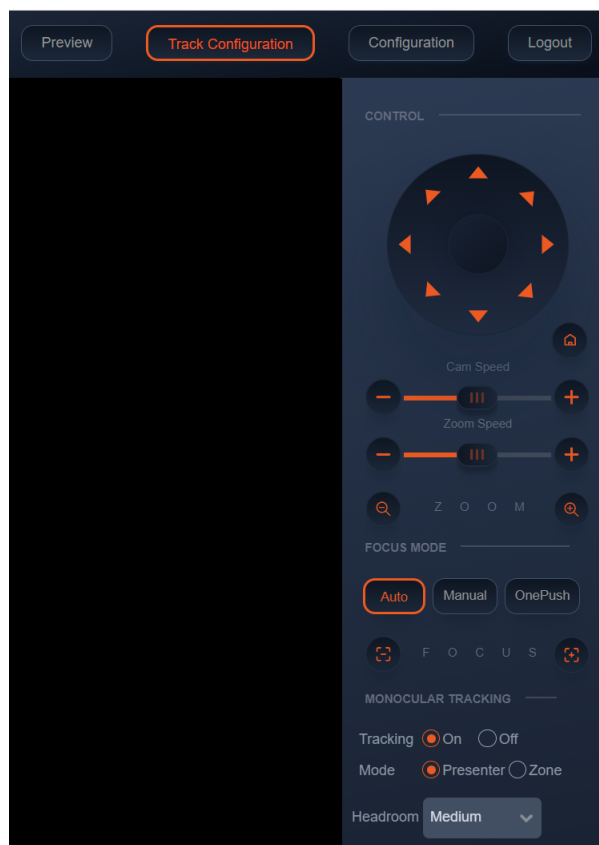

To set up or enable auto-tracking, select “**Track Configuration**” on the top right corner.

Select “**On**” under the option for Monocular Tracking.

You have 2 modes for tracking:

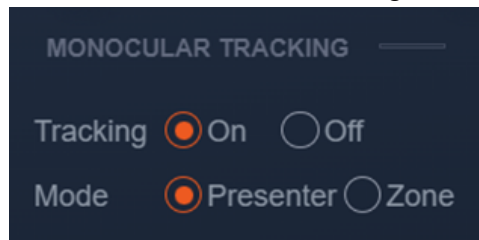

**Presenter:** The camera will continuously follow the subject until either the subject moves beyond the camera’s physical range of motion, a new more prominent target is in frame, or the tracking is disabled.

**Headroom:** Select from Low, Medium (default), or High settings to adjust space the tracking subject (only available in Presenter mode)

**Zone:** The camera holds its frame in predetermined zones. The camera tracks and moves only when the subject has left one zone and entered the next, then holds the frame in the new zone. If the subject exits the preset zones entirely, the camera will reset to the first zone or the Tracking Lost Preset if it was configured. The minimum zone allowance is 2 and the maximum is 4 zones. The zone size limits are  $-170^{\circ} \sim +170^{\circ}$  horizontal, and  $-30^{\circ} \sim +90^{\circ}$  vertical. See the next section “Zone Tracking Setup” for instructions.



## ZONE TRACKING SETUP

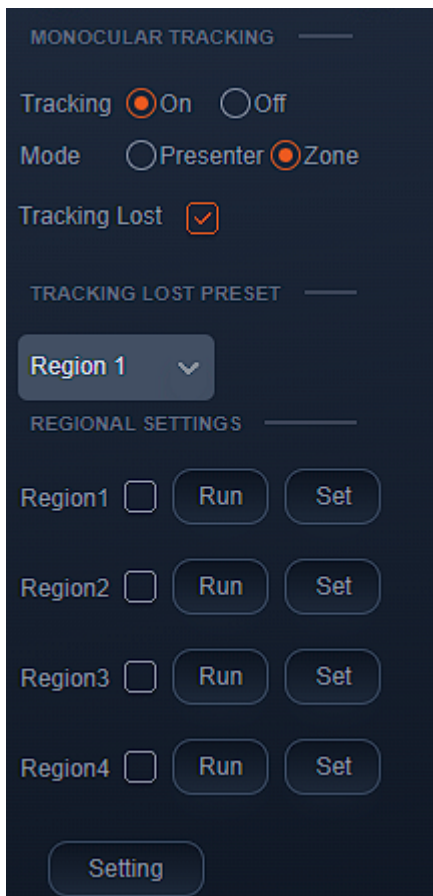

- Zone tracking must be set up using the web interface. However, it can be activated using the remote once the setup process has been completed.
- Using either the remote or web interface, adjust the camera to the desired shot.
- Select “Set” to save the shot on the desired region.
- Preset images will be shown below the preview image.
- Click the Check box on the region to enable tracking for the new zone and to save the preset.
- For zone tracking to work perform the steps again for at least 1 more region up to a total of 4.
- Use the “Tracking Lost Preset” to configure which region or Home position the camera will return to if tracking is lost.

**Note:** Each preset preview image must be continuous from left to right and overlap when setting the tracking regions. See the picture below for an example:

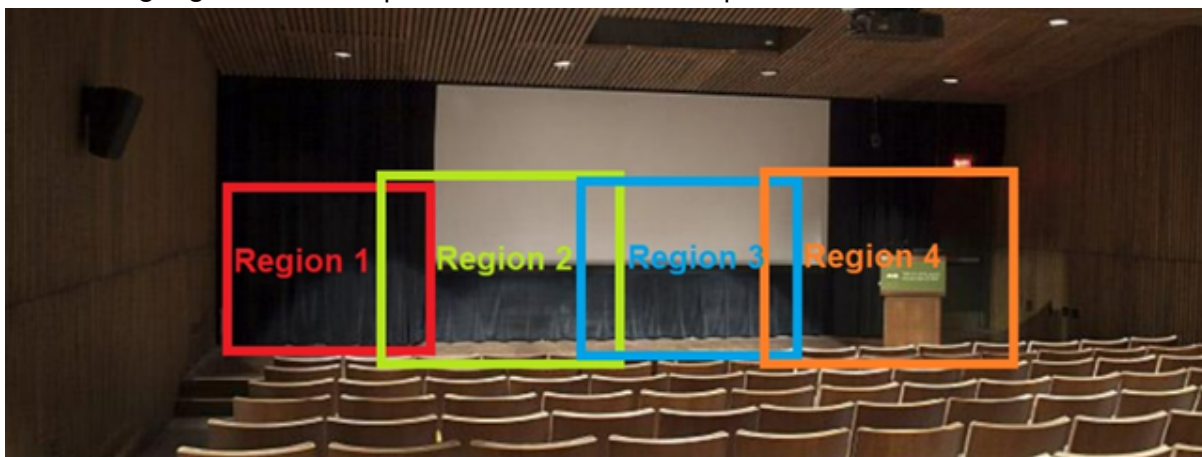





## General Configuration

To access system settings select “**Configuration**” in the top left corner of the web interface.

**CONFIGURATIONS**

**AUDIO CONFIGURE**

VIDEO CONFIGURE

Video Encode

Stream Publish

Multicast/Unicast

Video Parameters

Video OSD

OSD Font Size

Video Out

NETWORK CONFIGURE

Network Port

Ethernet

DNS

GB28181

SRT

RTSP

SYSTEM CONFIGURE

SystAttr

SysTime

SysUser

Update

Default

Reboot

### Audio Configure

Enable

Encode Type AAC

Sample Rate 48000

Sample Bits 16

Bit Rate 64Kbps

Channel Mono

Input Volume

Save

| Menu              | Explanation   |
|-------------------|---|
| Audio Configure   | Includes audio compression formats, sampling frequency, sampling precision, compressing code rate settings etc.   |
| Video Configure   | Includes video encoding, video parameters, character-overlapping, character size, video output setting etc.   |
| Network Configure | Includes Network Ports for video formats, Ethernet static or DHCP, DNS, GB28181, SRT, and RTSP  |
| System Configure  | Includes system attributes (device name/ID), system time, auto reboot scheduler, user management, firmware update, reboot, and restore factory defaults |



## Audio Configure

- **Enable:** Check the Enable box to turn on embedded audio into the camera stream.
- **Encode Type:** Select the audio format (AAC only at this time).
- **Sample Rate:** 48kHz (not editable)
- **Sample Bits:** 16bit (not editable)
- **Bit Rate:** 32Kbps - 128Kbps
- **Channel:** Mono or Stereo
- **Input Volume:** Change the input volume from the source device to avoid distortion.

## Video Encode and Streaming

### Video Encode

| Stream            | Main Stream | Sub Stream |
|-------------------|-------------|------------|
| Compressed Format | H.264       | H.264      |
| Profile           | HP          | HP         |
| Image Size        | 1920*1080   | 720*480    |
| Rate Control      | CBR         | CBR        |
| Bit Rate(Kb/s)    | 8192        | 1024       |
| Frame Rate(F/S)   | 25          | 25         |
| I Frame Interval  | 25          | 25         |
| I Frame Min QP    | 20          | 20         |
| Stream Name       | live/av0    | live/av1   |

Covered by one or more claims of the HEVC patents listed at [patentlist.accessadvance.com](http://patentlist.accessadvance.com)





From the Video Encode tab users can edit the following parameters for the main and sub streams:

**Compressed Format:** H.264 (default) or H.265

**Profile:** HP or MP

**Image Size:** 1280x720 - 3840x2160 (Main Stream) 320x240 - 720x480 (Sub Stream)

**Rate Control:** CBR (Constant bit rate) or VBR (Variable Bit Rate)

**Bit Rate:** Default 8192 Kb/s (recommended for 3840x2160)

**Frame Rate (F/S):** Default is 25

**I Frame Interval:** Default is 25

**I Frame Min QP:** Default is 20

**Stream Name:** Default is “live/av0” or “live/av1”

## VIDEO STREAM CAPTURE

Navigate to Configuration -> Video Encode

The screenshot shows the 'Video Encode' configuration page. On the left is a sidebar with navigation options: CONFIGURATIONS, AUDIO CONFIGURE, VIDEO CONFIGURE, Video Encode (highlighted), Stream Publish, Multicast/Unicast, Video Parameters, Video OSD, OSD Font Size, Video Out, NETWORK CONFIGURE, Network Port, Ethernet, DNS, GB28181, SRT, RTSP, and SYSTEM CONFIGURE, SystAttr, SysTime, SysUser, Update, Default, and Reboot. The main area is titled 'Video Encode' and has two columns: 'Main Stream' and 'Sub Stream'. Parameters for each stream include: Compressed Format (H.264), Profile (HP), Image Size (1920\*1080 for Main, 720\*480 for Sub), Rate Control (CBR), Bit Rate (Kb/s) (8192 for Main, 1024 for Sub), Frame Rate (F/S) (25), I Frame Interval (25), and I Frame Min QP (10). The 'Stream Name' field is circled in red, with 'live/av0' for the Main Stream and 'live/av1' for the Sub Stream. A 'Save' button is at the bottom.

| Parameter         | Main Stream | Sub Stream |
|-------------------|-------------|------------|
| Compressed Format | H.264       | H.264      |
| Profile           | HP          | HP         |
| Image Size        | 1920*1080   | 720*480    |
| Rate Control      | CBR         | CBR        |
| Bit Rate(Kb/s)    | 8192        | 1024       |
| Frame Rate(F/S)   | 25          | 25         |
| I Frame Interval  | 25          | 25         |
| I Frame Min QP    | 10          | 10         |
| Stream Name       | live/av0    | live/av1   |

Configure the parameters according to your network environment.

**Note:** stream name - live/av0 (live/ XXX)



### For example:

The default IP address of the camera is 192.168.5.163. To obtain the RTSP video stream, see below:

rtsp://192.168.5.163:554/live/av0 (av0 main stream)

rtsp://192.168.5.163:554/live/av1 (av1 sub stream)

The default IP address of the camera is 192.168.5.163. To obtain the RTMP video stream, see below:

rtmp://192.168.5.163:1935/live/av0 (av0 main stream)

rtmp://192.168.5.163:1935/live/av1 (av1 sub stream)

## LIVE STREAM PUBLISH

Navigate to Configuration -> Audio Configure

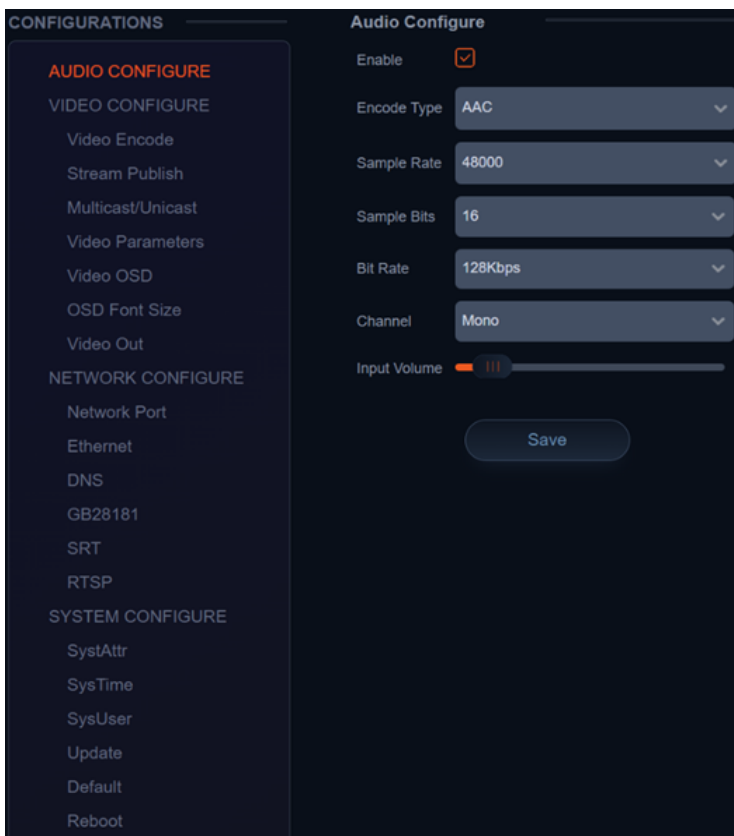

Ensure the check box next to “Enable” is toggled.

- Select AAC as the “Encode Type.”
- Change “Bit Rate” to 128Kbps to ensure the highest audio quality.
- Click Save and Reboot the camera.

**Note:** It may be necessary to adjust the “Image Size” under “Video Encode” to 1920x1080 or below to live stream due to bandwidth limitations on certain platforms.



Navigate to Configuration -> Stream Publish

- To push an RTMP stream to a public network, such as Facebook or YouTube, the camera must be connected to a network otherwise it will fail to connect to a server.
- **Host Address:** Server address, domain name, or an IP address.
- **Host Port:** Server default port number (Facebook 443 / YouTube 1935).
- **Stream Name:** Stream key provided by streaming platform.
- **Username and Password:** Leave blank as they are set by the server.
- Click "Save"

## Multicast/Unicast

Use the Multicast / Unicast tab to control the following settings:

**Enable:** Check the box to enable or disable the Main or Sub streams

**Protocol Type:** Select the Multicast or Unicast protocol (RTP Multicast, TS Multicast, UDP Unicast, TCP Unicast)

**Address:** Set the IP address for the stream.

**Port:** Set the port for the stream

**Access Method:** Displays the full link that can be used to access the stream when enabled.



## Video Parameters

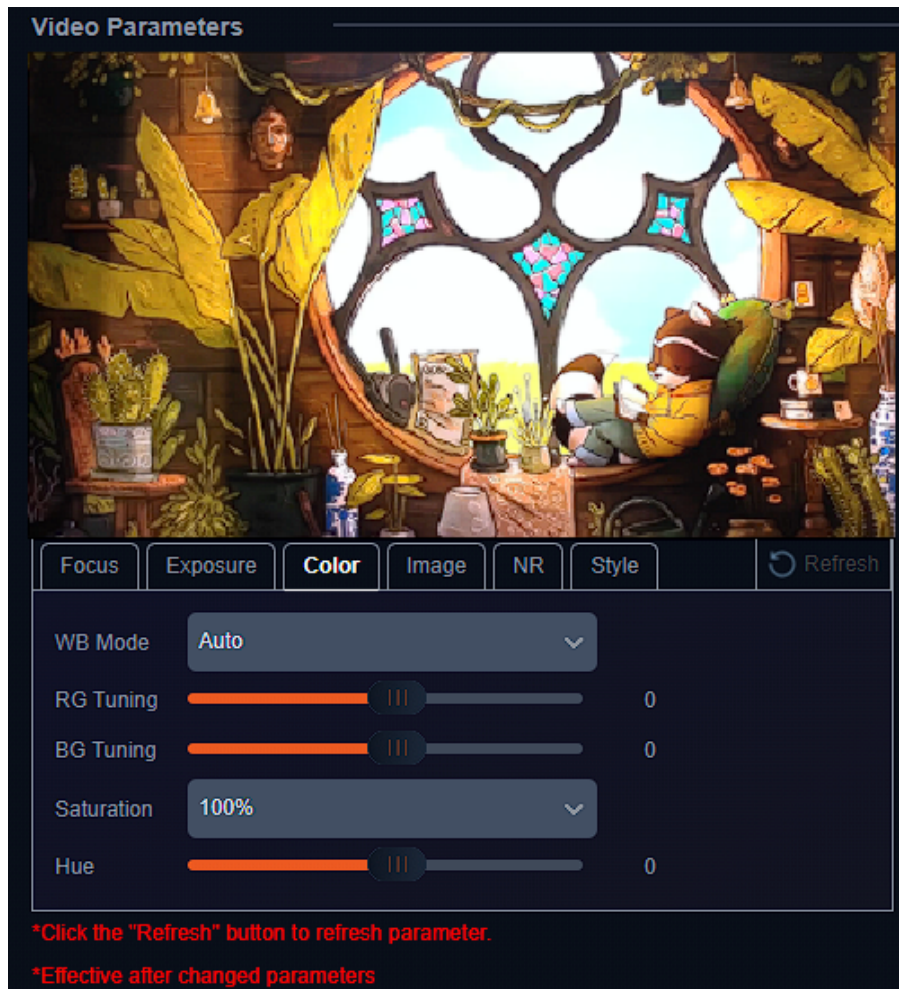

From the Video Parameters tab users have several options to manually control the image captured from the camera. Controls are broken into 6 sub sections: Focus, Exposure, Color, Image, NR, and Style. A preview image is shown above the settings so users can see their changes in real time.

### Focus



**Focus Mode:** Auto, Manual, OnePush

**AF-Zone:** Top, Center, Bottom, or All tells the camera which area of the shot is the primary point of focus.

**AF-Sensitivity:** Low, Middle, High changes how often the

camera attempts to refocus when the mode is set to Auto.



## Exposure

Depending on the Exposure mode selected different control options will be displayed as shown below:

### Auto

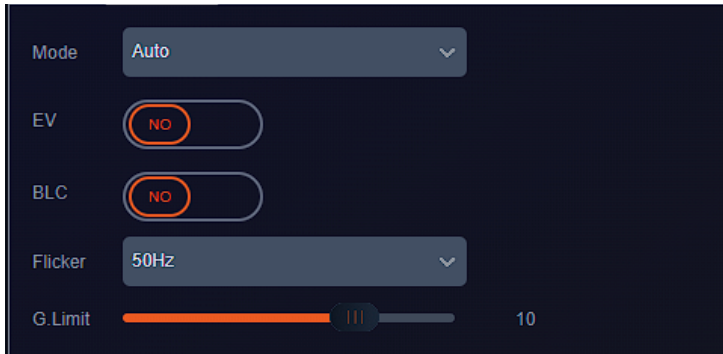

### Manual

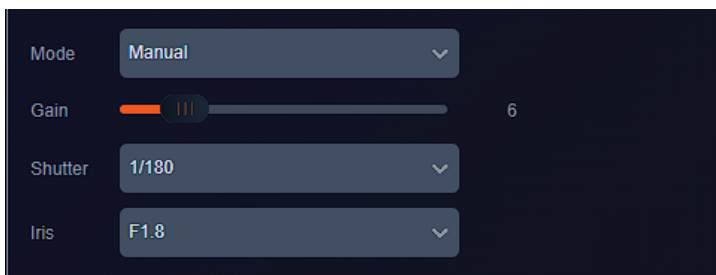

### SAE

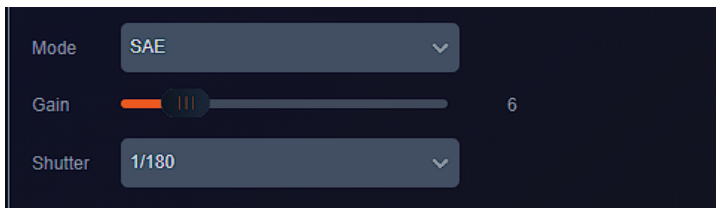

### AAE

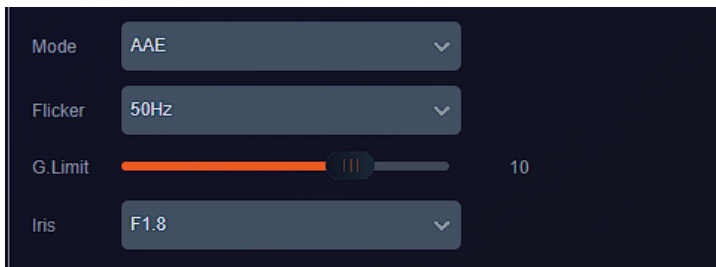

### Bright

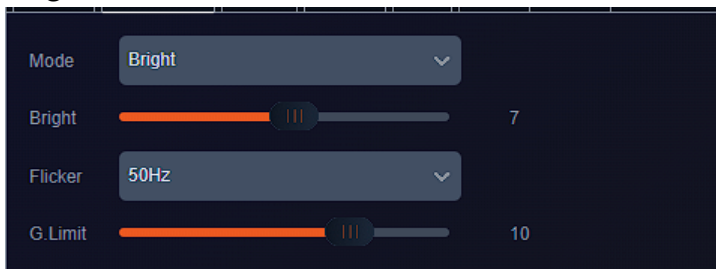



## Color

By default the WB Mode (White Balance) is set to Auto. Color temperatures from 2400K - 7100K, Manual, or OnePush are selectable. Options will change depending on the mode selected as shown below:

### Auto and Manual

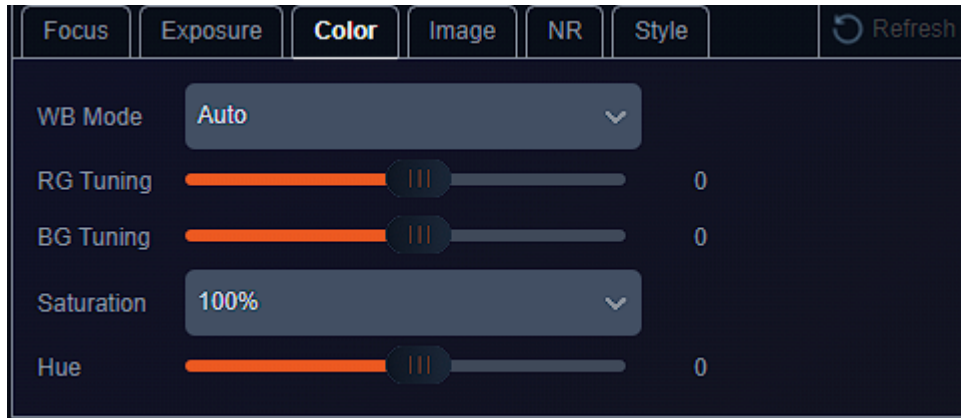

### Color Temperature 2400K - 7100K

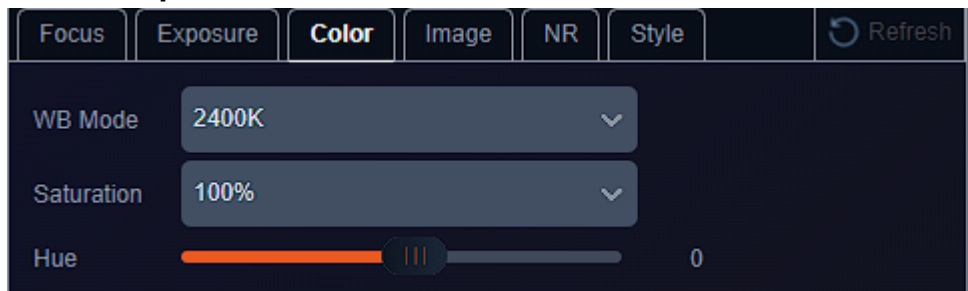

### OnePush

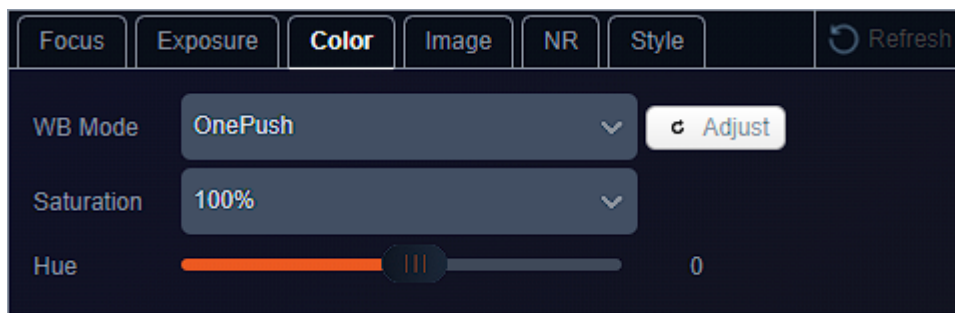

Press the “Adjust” button to lock in new white balance settings. This setting is useful when a white balance card is used.





## Image

From the Image tab users can control settings such as image Brightness, Contrast, Sharpness, B&W Mode (Black and white), Flip-H, Flip-V, Auto Flip, DZoom (digital zoom).

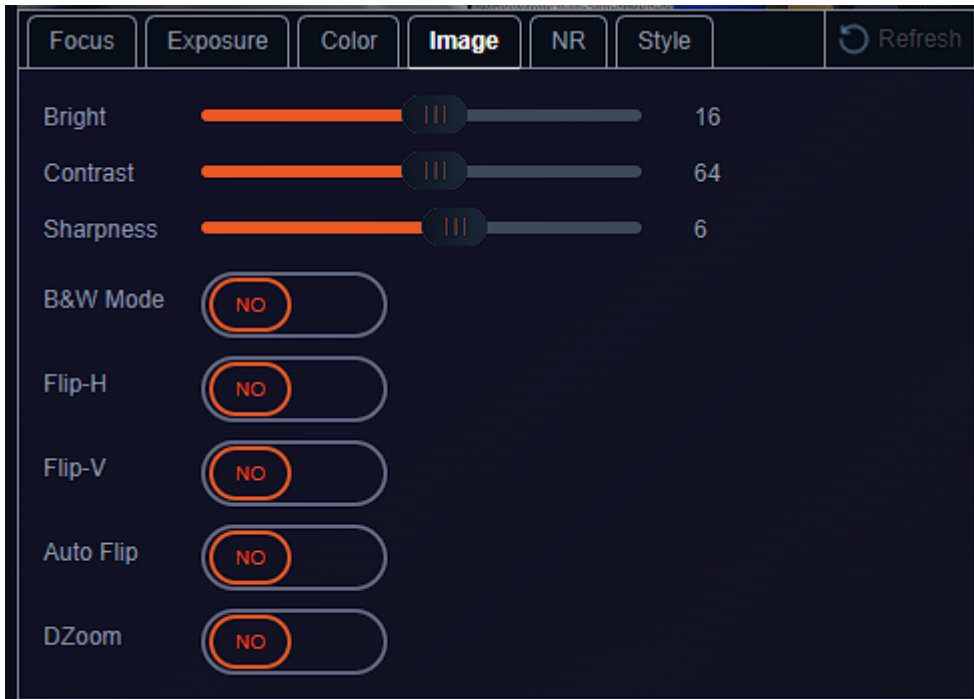

**Note:** Flip-H and Flip-V are only available when Auto Flip is disabled. DZoom allows the camera to digitally zoom in on a shot past the standard optical zoom range but may reduce image quality.

## NR

The NR-3D setting are intended to aid in reducing “noise” in an image caused by lighting.

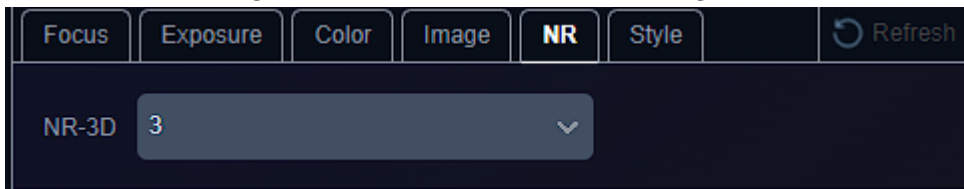

## Style

Style is used to select a preset configuration of camera parameters. Options include: Default, Meeting, Clarity, Bright, and Soft.

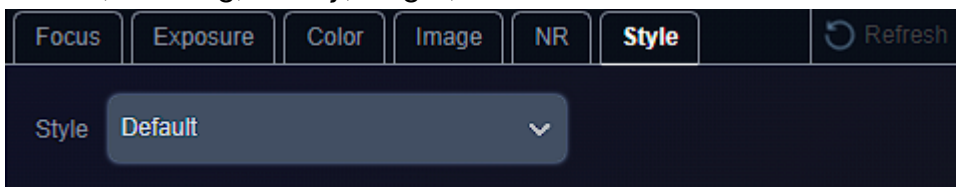



## Video OSD and OSD Font

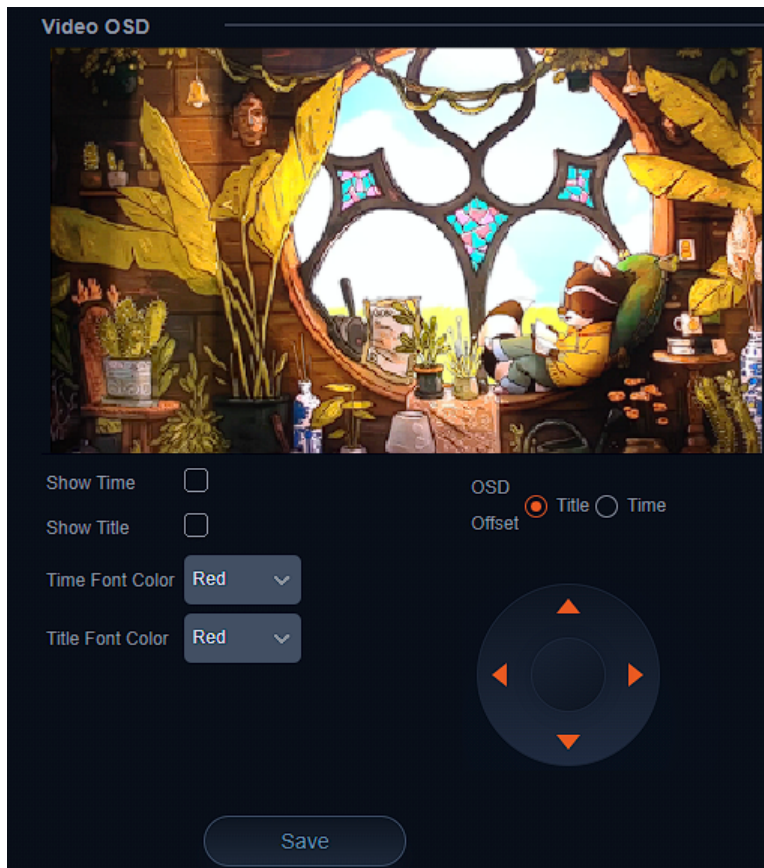

Video OSD or On Screen Display gives users the option to display the Device Name, Date, and Time, on the stream of the camera. This can be useful in easily identifying cameras when multiple are in use simultaneously in a production or security type setup.

Font colors and text locations can be edited using the drop downs and control options. Time and Title will appear once the options are enabled and saved.

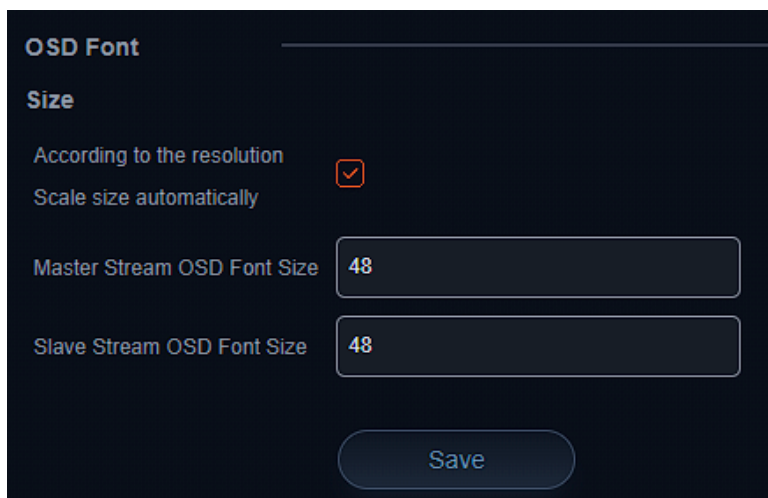

OSD Font is used to adjust the size of the OSD text.





## Video Out

---

Video Out

Video Out Format 1080P60

Save

Video Out is used to adjust output resolution of the camera to its physical HDMI and SDI outputs.

**Note:** To adjust NDI, Dante, RTSP stream, USB, and SD Capture resolutions, use the Video Encode Main or Sub stream setting “Image Size.”

## Network Configure

---

### Network Port

---

Network Port

Port Data 3000

Port Web 80

Port Onvif 2000

Port Soap 1936

Port RTMP 1935

Port Rtsps 554

Port Visca 1259

Port Https 443

Port WebSocket 8088

Save

Network Port allows users to modify port settings for various camera streams. The port follows the IP address but before stream specific information when connecting to various stream types.

**Example:** `rtsp://192.168.5.163:554/live/av0`  
:554 is the port

Depending on your network configuration some ports may be blocked, unavailable, or unreachable. It may be necessary to contact your network administrator to resolve these types of issues.



## Ethernet

**Ethernet**

DHCP

IP Address

Subnet Mask

Default Gateway

MAC Address

Ethernet settings allow users to change or modify how the camera is accessed on the network.

### DHCP

If the DHCP box is enabled, the local network will automatically assign an IP address to the camera the next time it is rebooted. This feature can also be enabled using the remote by pressing \* + \* + 1 or disabled by pressing \* + \* + 2.

The current IP address of the camera is displayed on start up when

connected to an external display via HDMI or SDI. It can also be displayed using the remote by pressing \* + \* + 3.

**NOTE:** It is highly recommended to turn DHCP off once an IP address is obtained from the network so the camera remains at a static, predictable, IP address for use with PTZ controllers, apps, and other devices.

## DNS

**DNS**

Preferred DNS Server

Alternative DNS Server

Allows users to change the Preferred and Alternate DNS server settings of the camera to a specific DNS server of their choice if required by their network.



## GB28181, SRT, and RTSP Authentication

**GB28181** is a camera protocol similar to ONVIF but uses Session Initiation Protocol (SIP).

These settings are typically used by particularly government entities and can be largely ignored by the standard user.

**SRT** is an alternative to standard RTSP streams. SRT can recover from packet loss of up to 15%. This provides a better video stream on substandard or congested networks. It also helps keep streams secure and easily traverses firewalls.

**RTSP Authentication** when enabled required users to enter the camera's login credentials directly into the RTSP stream URL to gain access as shown:  
rtsp://USER:PASS@[IP]:port/stream info.

**Default settings example:**

rtsp://admin:admin@192.168.5.163:554/live/av0



## System Configure

### System Attribute, System Time, & System User

**SYSTEM ATTRIBUTE**

Device Name: CAMERA-1

Device ID: 1

Language: English

Save

**System Attribute** allows users to edit the Device Name of the camera which can be helpful when identifying devices through enterprise level networks.

**System Time**

Date Format: YYYY-MM-DD

Date Separator: /

Zone: (GMT+08:00)Beijing, Hongkong, Sing

Hour Type: 24 Hours

NTP Enable:

Update Interval: 1 day

Host Url: time.nist.gov

Host Port: 123

Save

**Time Settings**

Time Settings: Synchronize with computer time

Computer Time: 2023-11-06 17:17:51

Sync.

**System Time** allows users to edit date and hour formats, time zones, hour type (24hr/12hr), if an NTP server is used or if the camera syncs to the connected computer via the web interface.

Camera time should be synchronized prior to using Auto Reboot to ensure accuracy.

**System User** allows Admin level users to edit usernames and passwords for up to 3 different users and set their authority level. Standard Users do not have access to any configuration settings. Admins have full control over the camera.



## Auto Reboot

Auto Reboot allows users to schedule the camera to automatically reboot on a certain time daily, once per week, or once per month. This is useful when the camera remains on constantly and helps to alleviate random system problems that may occur over time,

The screenshot displays the 'Auto Reboot' configuration interface with three distinct settings sections:

- Section 1:** 'Auto Reboot' is disabled. The 'Schedule' is set to 'Daily' (selected). The 'Time' is set to '12:00 AM'. A 'Save' button is visible below the settings.
- Section 2:** 'Auto Reboot' is disabled. The 'Schedule' is set to 'Weekly' (selected). The 'Repeat On' days are 'M', 'T', 'W', 'T', 'F', 'S', 'S'. The 'Time' is set to '12:00 AM'.
- Section 3:** 'Auto Reboot' is disabled. The 'Schedule' is set to 'Monthly' (selected). The 'On Date' is set to '1' and the 'Time' is set to '12:00 AM'.



## Operation System

---

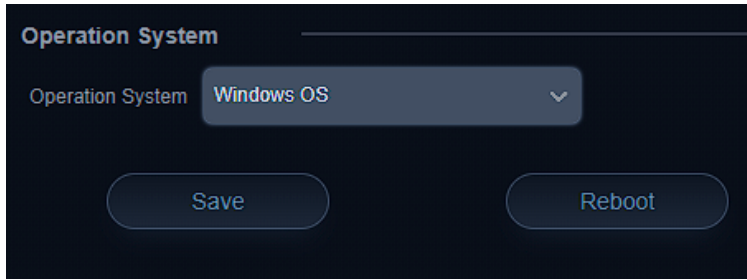

**Operation System** is used to control and limit the USB output resolution and refresh rate when connecting to Windows OS or MAC OS platforms to ensure the best possible performance.

## Update, Default, & Reboot

---

**Update** shows the camera's current firmware information and also allows users to upload new firmware to the camera.

**Default** is used to restore the camera to its factory default settings. This includes all network settings, image parameters, presets, etc.

**Reboot** is used to power cycle the camera via the web interface without having to unplug any cables or use the physical power switch on the back of the device.



## Serial Port Communication and Control

The camera can be controlled through an RS232/RS485 interface. RS232C serial parameters are as follows: Baud rate: 2400/4800/9600/115200 bits / sec; Start bit: 1; data bits: 8; Stop bit: 1; Parity: None

## VISCA Protocol List

### VISCA PROTOCOL RETURN COMMAND

| Ack/Completion Message |                |  |
|------------------------|----------------|--|
|                        | Command packet | Note   |
| ACK                    | z0 41 FF       | Returned when the command is accepted.       |
| Completion             | z0 51 FF       | Returned when the command has been executed. |

z= camera address + 8

| Error Messages         |                |   |
|------------------------|----------------|---|
|                        | Command packet | Note  |
| Syntax Error           | z0 60 02 FF    | Returned when the command format is different or when a command with illegal command parameters is accepted   |
| Command Not Executable | z0 61 41 FF    | Returned when a command cannot be executed due to current conditions. For example, when commands controlling the focus manually are received during auto focus. |

### VISCA PROTOCOL CONTROL COMMANDS

| Command       | Function       | Command packet             | Note                 |
|---------------|----------------|----------------------------|----------------------|
| AddressSet    | Broadcast      | 88 30 0p FF                | p: Address setting   |
| IF_Clear      | Broadcast      | 88 01 00 01 FF             | I/F Clear            |
| CommandCancel |                | 8x 21 FF                   |                      |
| CAM_Power     | On             | 8x 01 04 00 02 FF          | Power ON/OFF         |
|               | Off            | 8x 01 04 00 03 FF          |                      |
| CAM_Zoom      | Stop           | 8x 01 04 07 00 FF          |                      |
|               | Tele(Standard) | 8x 01 04 07 02 FF          |                      |
|               | Wide(Standard) | 8x 01 04 07 03 FF          |                      |
|               | Tele(Variable) | 8x 01 04 07 2p FF          |                      |
|               | Wide(Variable) | 8x 01 04 07 3p FF          |                      |
|               | Direct         | 8x 01 04 47 0p 0q 0r 0s FF | p = 0(low) - F(high) |
| CAM_Focus     | Stop           | 8x 01 04 07 00 FF          |                      |



| Command        | Function        | Command packet                            | Note  |
|----------------|-----------------|---|---|
|                | Far(Standard)   | 8x 01 04 08 00 FF                         |   |
|                | Near(Standard)  | 8x 01 04 08 02 FF                         |   |
|                | Far(Variable)   | 8x 01 04 08 03 FF                         | p = 0(low) - F(high)                        |
|                | Near (Variable) | 8x 01 04 08 2p FF                         |   |
|                | Direct          | 8x 01 04 08 3p FF                         | pqrs: Focus Position                        |
|                | Auto Focus      | 8x 01 04 48 0p 0q 0r 0s FF                |   |
|                | Manual Focus    | 8x 01 04 38 03 FF                         |   |
|                | One Push mode   | 8x 01 04 38 04 FF                         |   |
| CAM_Zoom Focus | Direct          | 8x 01 04 47 0p 0q 0r 0s<br>0t 0u 0v 0w FF | pqrs: Zoom Position<br>tuvw: Focus Position |
| CAM_WB         | Auto            | 8x 01 04 35 00 FF                         |   |
|                | 3000K           | 8x 01 04 35 01 FF                         |   |
|                | 4000k           | 8x 01 04 35 02 FF                         |   |
|                | One Push mode   | 8x 01 04 35 03 FF                         |   |
|                | 5000k           | 8x 01 04 35 04 FF                         |   |
| CAM_WB (cont.) | Manual          | 8x 01 04 35 05 FF                         |   |
|                | 6500k           | 8x 01 04 35 06 FF                         |   |
|                | 3500K           | 8x 01 04 35 07 FF                         |   |
|                | 4500K           | 8x 01 04 35 08 FF                         |   |
|                | 5500K           | 8x 01 04 35 09 FF                         |   |
|                | 6000K           | 8x 01 04 35 0A FF                         |   |
|                | 7000K           | 8x 01 04 35 0B FF                         |   |

| Command   | Function         | Command packet             | Note                                     |
|-----------|------------------|----------------------------|--|
| CAM_RGain | Reset            | 8x 01 04 03 00 FF          | Manual Control of R Gain                 |
|           | Up               | 8x 01 04 03 02 FF          |  |
|           | Down             | 8x 01 04 03 03 FF          |  |
|           | Direct           | 8x 01 04 43 00 00 0p 0q FF | pq: R Gain                               |
| CAM_Bgain | Reset            | 8x 01 04 04 00 FF          | Manual Control of B Gain                 |
|           | Up               | 8x 01 04 04 02 FF          |  |
|           | Down             | 8x 01 04 04 03 FF          |  |
|           | Direct           | 8x 01 04 44 00 00 0p 0q FF | pq: B Gain                               |
| CAM_AE    | Full Auto        | 8x 01 04 39 00 FF          | Automatic Exposure mode                  |
|           | Manual           | 8x 01 04 39 03 FF          | Manual Control mode                      |
|           | Shutter priority | 8x 01 04 39 0A FF          | Shutter Priority Automatic Exposure mode |
|           | Iris priority    | 8x 01 04 39 0B FF          | Iris Priority Automatic Exposure mode    |
|           | Bright           | 8x 01 04 39 0D FF          | Bright mode                              |





| Command         | Function   | Command packet             | Note                                 |
|-----------------|------------|----------------------------|--------------------------------------|
|                 | Full Auto  | 8x 01 04 39 00 FF          | Automatic Exposure mode              |
| CAM_Shutter     | Reset      | 8x 01 04 0A 00 FF          | Shutter Setting                      |
|                 | Up         | 8x 01 04 0A 02 FF          |                                      |
|                 | Down       | 8x 01 04 0A 03 FF          |                                      |
|                 | Direct     | 8x 01 04 4A 00 00 0p 0q FF | pq: Shutter Position                 |
| CAM_Iris        | Reset      | 8x 01 04 0B 00 FF          | Iris Setting                         |
|                 | Up         | 8x 01 04 0B 02 FF          |                                      |
|                 | Down       | 8x 01 04 0B 03 FF          |                                      |
|                 | Direct     | 8x 01 04 4B 00 00 0p 0q FF | pq: Iris Position                    |
| CAM_Gain Limit  | Gain Limit | 8x 01 04 2C 0p FF          | p: Gain Position                     |
|                 | Reset      | 8x 01 04 0D 00 FF          |                                      |
| CAM_Bright      | Up         | 8x 01 04 0D 02 FF          |                                      |
|                 | Down       | 8x 01 04 0D 03 FF          | Bright Setting                       |
|                 | Direct     | 8x 01 04 4D 00 00 0p 0q FF | pq: Bright Position                  |
| CAM_ExpComp     | On         | 8x 01 04 3E 02 FF          | Exposure Compensation ON/OFF         |
|                 | Off        | 8x 01 04 3E 03 FF          |                                      |
|                 | Reset      | 8x 01 04 0E 00 FF          | Exposure Compensation Amount Setting |
|                 | Up         | 8x 01 04 0E 02 FF          |                                      |
| CAM_ExpComp     | Down       | 8x 01 04 0E 03 FF          |                                      |
|                 | Direct     | 8x 01 04 4E 00 00 0p 0q FF | pq: ExpComp Position                 |
| CAM_Back Light  | On         | 8x 01 04 33 02 FF          | Back Light Compensation              |
|                 | Off        | 8x 01 04 33 03 FF          |                                      |
| CAM_WDRStrength | Reset      | 8x 01 04 21 00 FF          | WDR Level Setting                    |
|                 | Up         | 8x 01 04 21 02 FF          |                                      |
|                 | Down       | 8x 01 04 21 03 FF          |                                      |

| Command                 | Function | Command packet             | Note   |
|-------------------------|----------|----------------------------|--|
| CAM_WDRStrength (cont.) | Direct   | 8x 01 04 51 00 00 00 0p FF | p: WDR Level Position                              |
| CAM_NR(2D)              |          | 8x 01 04 53 0p FF          | P=0-7 0:OFF  |
| CAM_NR(3D)              |          | 8x 01 04 54 0p FF          | P=0-8 0:OFF  |
| CAM_Gamma               |          | 8x 01 04 5B 0p FF          | p = 0 – 40: Default 1:0.45 2:0.50<br>3:0.55 4:0.63 |
| CAM_Flicker             | OFF      | 8x 01 04 23 00 FF          | OFF  |
|                         | 50HZ     | 8x 01 04 23 01 FF          | 50HZ   |
|                         | 60HZ     | 8x 01 04 23 02 FF          | 60HZ   |
| CAM_Aperture            | Reset    | 8x 01 04 02 00 FF          | Aperture Control                                   |
|                         | Up       | 8x 01 04 02 02 FF          |  |
|                         | Down     | 8x 01 04 02 03 FF          |  |



| Command             | Function | Command packet             | Note  |
|---------------------|----------|----------------------------|---|
|                     | Direct   | 8x 01 04 42 00 00 0p 0q FF | pq: Aperture Gain   |
| CAM_Memory          | Reset    | 8x 01 04 3F 00 pq FF       | pq: Memory Number(=0 to 254)<br>Corresponds to 0 to 9 on the Remote Commander   |
|                     | Set      | 8x 01 04 3F 01 pq FF       |   |
|                     | Recall   | 8x 01 04 3F 02 pq FF       |   |
| CAM_LR_Reverse      | On       | 8x 01 04 61 02 FF          | Image Flip Horizontal ON/OFF  |
|                     | Off      | 8x 01 04 61 03 FF          |   |
| CAM_PictureFlip     | On       | 8x 01 04 66 02 FF          | Image Flip Vertical ON/OFF  |
|                     | Off      | 8x 01 04 66 03 FF          |   |
| CAM_ColorSaturation | Direct   | 8x 01 04 49 00 00 00 0p FF | P=0-E<br>0:60% 1:70% 2:80% 3:90% 4:100%<br>5:110% 6:120% 7:130% 8:140%<br>9:150% 10:160% 11:160%<br>12:180% 13:190% 14:200% |
| CAM_IDWrite         |          | 8x 01 04 22 0p 0q 0r 0s FF | pqrs: Camera ID (=0000 to FFFF)   |
| SYS_Menu            | ON       | 8x 01 04 06 06 02 FF       | Turn on the menu screen   |
|                     | OFF      | 8x 01 04 06 06 03 FF       | Turn off the menu screen  |
| IR_Receive          | ON       | 8x 01 06 08 02 FF          | IR(remote commander)receive On/Off  |
|                     | OFF      | 8x 01 06 08 03 FF          |   |
| IR_ReceiveReturn    | On       | 8x 01 7D 01 03 00 00 FF    | IR(remote commander)receive message via   |
|                     | Off      | 8x 01 7D 01 13 00 00 FF    |   |
| IR_ReceiveReturn    | Reset    | 8x 01 04 A0 10 FF          | Reset Factory Setting   |
| CAM_Brightness      | Direct   | 8x 01 04 A1 00 00 0p 0q FF | pq: Brightness Position   |
| CAM_Contrast        | Direct   | 8x 01 04 A2 00 00 0p 0q FF | pq: Contrast Position   |
| CAM_Flip            | OFF      | 8x 01 04 A4 00 FF          | Single Command For Video Flip   |
|                     | Flip-H   | 8x 01 04 A4 01 FF          |   |
|                     | Flip-V   | 8x 01 04 A4 02 FF          |   |
|                     | Flip-HV  | 8x 01 04 A4 03 FF          |   |

| Command         | Function                | Command packet             | Note  |
|-----------------|-------------------------|----------------------------|---|
| CAM_VideoSystem | Set camera video system | 8x 01 06 35 00 0p FF       | P: 0~E Video format<br>0:1080P60 8:720P30<br>1:1080P50 9:720P25<br>2:1080i60 A: 1080P59.94<br>3:1080i50 B: 1080i59.94<br>4:720P60 C: 720P59.94<br>5:720P50 D: 1080P29.97<br>6:1080P30 E: 720P29.97<br>7:1080P25 |
| Pan_tiltDrive   | Up                      | 8x 01 06 01 VV WW 03 01 FF | VV: Pan speed 0x01 (low speed) to 0x18 (high speed)<br>WW: Tilt speed 0x01 (low speed) to 0x14 (high speed)<br>YYYY: Pan Position ZZZZ: Tilt Position   |
|                 | Down                    | 8x 01 06 01 VV WW 03 02 FF |   |
|                 | Left                    | 8x 01 06 01 VV WW 01 03 FF |   |
|                 | Right                   | 8x 01 06 01 VV WW 02 03 FF |   |



| Command          | Function         | Command packet                                  | Note  |
|------------------|------------------|---|---|
|                  | Upleft           | 8x 01 06 01 VV WW 01 01 FF                      |   |
|                  | Upright          | 8x 01 06 01 VV WW 02 01 FF                      |   |
|                  | DownLeft         | 8x 01 06 01 VV WW 01 02 FF                      |   |
|                  | DownRight        | 8x 01 06 01 VV WW 02 02 FF                      |   |
|                  | Stop             | 8x 01 06 01 VV WW 03 03 FF                      |   |
|                  | AbsolutePosition | 8x 01 06 02 VV WW<br>0Y 0Y 0Y 0Y 0Z 0Z 0Z 0Z FF |   |
|                  | RelativePosition | 8x 01 06 03 VV WW<br>0Y 0Y 0Y 0Y 0Z 0Z 0Z 0Z FF |   |
|                  | Home             | 8x 01 06 04 FF                                  |   |
|                  | Reset            | 8x 01 06 04 FF                                  |   |
| Pan-tiltLimitSet | Set              | 8x 01 06 07 00 0W<br>0Y 0Y 0Y 0Y 0Z 0Z 0Z 0Z FF | 8x 01 06 07 01 0W<br>07 0F 0F 0F 07 0F 0F 0F FF |
|                  | Clear            | 8x 01 06 07 01 0W<br>07 0F 0F 0F 07 0F 0F 0F FF |   |

| Command           | Function               | Command packet             | Note                  |
|-------------------|------------------------|----------------------------|-----------------------|
| Red On            | Tally Light On         | 81 01 7E 01 0A 00 02 00 FF | Red Tally Light On    |
| Red Off           | Tally Light Off        | 81 01 7E 01 0A 00 03 00 FF | Red Tally Light Off   |
| Green On          | Tally Light On         | 81 01 7E 01 0A 00 00 02 FF | Green Tally Light On  |
| Green Off         | Tally Light Off        | 81 01 7E 01 0A 00 00 03 FF | Green Tally Light Off |
| Auto Tracking On  | Auto Tracking Mode On  | 8x 0A 01 32 00 00 02 00 FF | Tracking Mode On      |
| Auto Tracking Off | Auto Tracking Mode Off | 8x 0A 01 32 00 00 03 00 FF | Tracking Mode Off     |

**VISCA PROTOCOL INQUIRY COMMANDS**

| Command             | Command Packet | Return Packet        | Note                 |
|---------------------|----------------|----------------------|----------------------|
| CAM_PowerInq        | 8x 09 04 00 FF | y0 50 02 FF          | On                   |
|                     |                | y0 50 03 FF          | Off(Standby)         |
| CAM_ZoomPosInq      | 8x 09 04 47 FF | y0 50 0p 0q 0r 0s FF | pqrs: Zoom Position  |
| CAM_FocusAFModelInq | 8x 09 04 38 FF | y0 50 02 FF          | Auto Focus           |
|                     |                | y0 50 03 FF          | Manual Focus         |
|                     |                | y0 50 04 FF          | One Push mode        |
| CAM_FocusPosInq     | 8x 09 04 48 FF | y0 50 0p 0q 0r 0s FF | pqrs: Focus Position |
| CAM_WBModelInq      | 8x 09 04 35 FF | y0 50 00 FF          | Auto                 |
|                     |                | y0 50 01 FF          | 3000K                |
|                     |                | y0 50 02 FF          | 4000K                |
|                     |                | y0 50 03 FF          | One Push Mode        |
|                     |                | y0 50 04 FF          | 5000K                |



| Command                  | Command Packet | Return Packet        | Note   |
|--------------------------|----------------|----------------------|--|
|                          |                | y0 50 05 FF          | Manual                                       |
|                          |                | y0 50 00 FF          | 6500K  |
|                          |                | y0 50 06 FF          | 6500K  |
|                          |                | y0 50 07 FF          | 3500K  |
|                          |                | y0 50 08 FF          | 4500K  |
|                          |                | y0 50 09 FF          | 5500K  |
|                          |                | y0 50 0A FF          | 6000K  |
| CAM_RGainInq             | 8x 09 04 43 FF | y0 50 0B FF          | 7000K  |
| CAM_BGainInq             | 8x 09 04 44 FF | y0 50 00 00 0p 0q FF | pq: B Gain                                   |
| CAM_AEModeInq            | 8x 09 04 39 FF | y0 50 00 FF          | Full Auto                                    |
|                          |                | y0 50 03 FF          | Manual                                       |
|                          |                | y0 50 0A FF          | Shutter priority                             |
|                          |                | y0 50 0B FF          | Iris priority                                |
| CAM_ShutterPosInq        | 8x 09 04 4A FF | y0 50 00 00 0p 0q FF | pq: Shutter Position                         |
| CAM_IrisPosInq           | 8x 09 04 4B FF | y0 50 00 00 0p 0q FF | pq: Iris Position                            |
| CAM_Gain LimitInq        | 8x 09 04 2C FF | y0 50 0p FF          | p: Gain Position                             |
| CAM_BrightPosInq         | 8x 09 04 4D FF | y0 50 00 00 0p 0q FF | pq: Bright Position                          |
| CAM_ExpCompModeInq       | 8x 09 04 3E FF | y0 50 02 FF          | On   |
|                          |                | y0 50 03 FF          | Off  |
| CAM_ExpCompPosInq        | 8x 09 04 4E FF | y0 50 00 00 0p 0q FF | pq: ExpComp Position                         |
| CAM_BacklightModeInq     | 8x 09 04 33 FF | y0 50 02 FF          | On   |
|                          |                | y0 50 03 FF          | Off  |
| CAM_WDRStrengthInq       | 8x 09 04 51 FF | y0 50 00 00 00 0p FF | p: WDR Strength                              |
| CAM_NRLevel(2D) Inq      | 8x 09 04 53 FF | y0 50 0p FF          | P: 2DNRLLevel                                |
| CAM_NRLevel(3D) Inq      | 8x 09 04 54 FF | y0 50 0p FF          | P:3D NRLevel                                 |
| CAM_FlickerModeInq       | 8x 09 04 55 FF | y0 50 0p FF          | p: Flicker Settings(0: OFF, 1: 50Hz, 2:60Hz) |
| CAM_ApertureInq          | 8x 09 04 42 FF | y0 50 00 00 0p 0q FF | pq: Aperture Gain                            |
| CAM_PictureEffectModeInq | 8x 09 04 63 FF | y0 50 00 FF          | Off  |
|                          |                | y0 50 04 FF          | B&W  |
| CAM_MemoryInq            | 8x 09 04 3F FF | y0 50 0p FF          | p: Memory number last operated.              |



| Command                | Command Packet | Return Packet                    | Note   |
|------------------------|----------------|----------------------------------|--|
| SYS_MenuModelInq       | 8x 09 06 06 FF | y0 50 02 FF                      | On   |
|                        |                | y0 50 03 FF                      | Off  |
| CAM_LR_ReverseInq      | 8x 09 04 61 FF | y0 50 02 FF                      | On   |
|                        |                | y0 50 03 FF                      | Off  |
| CAM_PictureFlipInq     | 8x 09 04 66 FF | y0 50 02 FF                      | On   |
|                        |                | y0 50 03 FF                      | Off  |
| CAM_ColorSaturationInq | 8x 09 04 49 FF | y0 50 00 00 00 0p FF             | p: Color Gain setting 0h (60%) to Eh (130%)  |
| CAM_IDInq              | 8x 09 04 22 FF | y0 50 0p FF                      | p: Gamma ID  |
| IR_ReceiveInq          | 8x 09 06 08 FF | y0 50 02 FF                      | On   |
|                        |                | y0 50 03 FF                      | Off  |
| IR_ReceiveReturn       |                | y0 07 7D 01 04 00 FF             | Power ON/OFF   |
|                        |                | y0 07 7D 01 04 07 FF             | Zoom tele/wide   |
|                        |                | y0 07 7D 01 04 38 FF             | AF ON/OFF  |
|                        |                | y0 07 7D 01 04 33 FF             | Camera _Backlight  |
|                        |                | y0 07 7D 01 04 3F FF             | Camera _Memery   |
|                        |                | y0 07 7D 01 06 01 FF             | Pan_titleDriver  |
| CAM_BrightnessInq      | 8x 09 04 A1 FF | y0 50 00 00 0p 0q FF             | pq: Brightness Position  |
| CAM_ContrastInq        | 8x 09 04 A2 FF | y0 50 00 00 0p 0q FF             | pq: Contrast Position  |
| CAM_FlipInq            | 8x 09 04 A4 FF | y0 50 00 FF                      | Off  |
|                        |                | y0 50 01 FF                      | Flip-H   |
|                        |                | y0 50 02 FF                      | Flip-V   |
|                        |                | y0 50 03 FF                      | Flip-HV  |
| CAM_GammaInq           | 8x 09 04 5B FF | y0 50 0p FF                      | p: Gamma setting   |
| CAM_VersionInq         | 8x 09 00 02 FF | y0 50 ab cd<br>mn pq rs tu vw FF | ab cd : vender ID ( 0220 )<br>mn pq : model ID ST ( 0510 ) 、<br>U2( 0512 )、 U3 ( 0513 )<br>rs tu : ARM Version vw : reserve  |
| VideoSystemInq         | 8x 09 06 23 FF | y0 50 0p FF                      | P: 0~E Video format 0:1080P60<br>8:720P30<br>1:1080P50<br>9:720P25<br>2:1080i60 A: 1080P59.94<br>3:1080i50 B: 1080i59.94<br>4:720P60 C: 720P59.94<br>5:720P50 D: 1080P29.97<br>6:1080P30 E: 720P29.97<br>7:1080P25 |
| Pan-tiltMaxSpeedInq    | 8x 09 06 11 FF | y0 50 ww zz FF                   | ww: Pan Max Speed      zz: Tilt<br>Max Speed   |
| Pan-tiltPosInq         | 8x 09 06 12 FF | y0 50 0w 0w 0w 0w 0z 0z 0z 0z FF | www: Pan Position      zzzz: Tilt<br>Position  |



**Note:** [X] in the above table indicates the camera address to be operated, [y]=[x + 8].

### PELCO-D PROTOCOL COMMAND LIST

| Function                     | Byte1 | Byte2   | Byte3 | Byte4 | Byte5           | Byte6          | Byte7 |
|------------------------------|-------|---------|-------|-------|-----------------|----------------|-------|
| Up                           | 0xFF  | Address | 0x00  | 0x08  | Pan Speed       | Tilt Speed     | SUM   |
| Down                         | 0xFF  | Address | 0x00  | 0x10  | Pan Speed       | Tilt Speed     | SUM   |
| Left                         | 0xFF  | Address | 0x00  | 0x04  | Pan Speed       | Tilt Speed     | SUM   |
| Right                        | 0xFF  | Address | 0x00  | 0x02  | Pan Speed       | Tilt Speed     | SUM   |
| Upleft                       | 0xFF  | Address | 0x00  | 0x0C  | Pan Speed       | Tilt Speed     | SUM   |
| Upright                      | 0xFF  | Address | 0x00  | 0x0A  | Pan Speed       | Tilt Speed     | SUM   |
| DownLeft                     | 0xFF  | Address | 0x00  | 0x14  | Pan Speed       | Tilt Speed     | SUM   |
| DownRight                    | 0xFF  | Address | 0x00  | 0x12  | Pan Speed       | Tilt Speed     | SUM   |
| Zoom In                      | 0xFF  | Address | 0x00  | 0x20  | 0x00            | 0x00           | SUM   |
| Zoom Out                     | 0xFF  | Address | 0x00  | 0x40  | 0x00            | 0x00           | SUM   |
| Focus Far                    | 0xFF  | Address | 0x00  | 0x80  | 0x00            | 0x00           | SUM   |
| Focus Near                   | 0xFF  | Address | 0x01  | 0x00  | 0x00            | 0x00           | SUM   |
| Stop                         | 0xFF  | Address | 0x00  | 0x00  | 0x00            | 0x00           | SUM   |
| Set Preset                   | 0xFF  | Address | 0x00  | 0x03  | 0x00            | Preset ID      | SUM   |
| Clear Preset                 | 0xFF  | Address | 0x00  | 0x05  | 0x00            | Preset ID      | SUM   |
| Call Preset                  | 0xFF  | Address | 0x00  | 0x07  | 0x00            | Preset ID      | SUM   |
| Query Pan Position           | 0xFF  | Address | 0x00  | 0x51  | 0x00            | 0x00           | SUM   |
| Query Pan Position Response  | 0xFF  | Address | 0x00  | 0x59  | Value High Byte | Value Low Byte | SUM   |
| Query Tilt Position          | 0xFF  | Address | 0x00  | 0x53  | 0x00            | 0x00           | SUM   |
| Query Tilt Position Response | 0xFF  | Address | 0x00  | 0x5B  | Value High Byte | Value Low Byte | SUM   |
| Query Zoom Position          | 0xFF  | Address | 0x00  | 0x55  | 0x00            | 0x00           | SUM   |
| Query Zoom Position Response | 0xFF  | Address | 0x00  | 0x5D  | Value High Byte | Value Low Byte | SUM   |



## PELCO-P PROTOCOL COMMAND LIST

| Function                     | Byte1 | Byte2   | Byte3 | Byte4 | Byte5           | Byte6          | Byte7 |
|------------------------------|-------|---------|-------|-------|-----------------|----------------|-------|
| Query Zoom Position Response | 0xFF  | Address | 0x00  | 0x5D  | Value High Byte | Value Low Byte | SUM   |
| Up                           | 0xA0  | Address | 0x00  | 0x08  | Pan Speed       | Tilt Speed     | 0xAF  |
| Down                         | 0xA0  | Address | 0x00  | 0x10  | Pan Speed       | Tilt Speed     | 0xAF  |
| Left                         | 0xA0  | Address | 0x00  | 0x04  | Pan Speed       | Tilt Speed     | 0xAF  |
| Right                        | 0xA0  | Address | 0x00  | 0x02  | Pan Speed       | Tilt Speed     | 0xAF  |
| Upleft                       | 0xA0  | Address | 0x00  | 0x0C  | Pan Speed       | Tilt Speed     | 0xAF  |
| Upright                      | 0xA0  | Address | 0x00  | 0x0A  | Pan Speed       | Tilt Speed     | 0xAF  |
| DownLeft                     | 0xA0  | Address | 0x00  | 0x14  | Pan Speed       | Tilt Speed     | 0xAF  |
| DownRight                    | 0xA0  | Address | 0x00  | 0x12  | Pan Speed       | Tilt Speed     | 0xAF  |
| Zoom In                      | 0xA0  | Address | 0x00  | 0x20  | 0x00            | 0x00           | 0xAF  |
| Zoom Out                     | 0xA0  | Address | 0x00  | 0x40  | 0x00            | 0x00           | 0xAF  |
| Stop                         | 0xA0  | Address | 0x00  | 0x00  | 0x00            | 0x00           | 0xAF  |
| Focus Far                    | 0xA0  | Address | 0x01  | 0x00  | 0x00            | 0x00           | 0xAF  |
| Focus Near                   | 0xA0  | Address | 0x02  | 0x00  | 0x00            | 0x00           | 0xAF  |
| Set Preset                   | 0xA0  | Address | 0x00  | 0x03  | 0x00            | Preset ID      | 0xAF  |
| Clear Preset                 | 0xA0  | Address | 0x00  | 0x05  | 0x00            | Preset ID      | 0xAF  |
| Call Preset                  | 0xA0  | Address | 0x00  | 0x07  | 0x00            | Preset ID      | 0xAF  |
| Query Pan Position           | 0xA0  | Address | 0x00  | 0x51  | 0x00            | 0x00           | 0xAF  |
| Query Pan Position Response  | 0xA0  | Address | 0x00  | 0x59  | Value High Byte | Value Low Byte | 0xAF  |
| Query Tilt Position          | 0xA0  | Address | 0x00  | 0x53  | 0x00            | 0x00           | 0xAF  |
| Query Tilt Position Response | 0xA0  | Address | 0x00  | 0x5B  | Value High Byte | Value Low Byte | 0xAF  |
| Query Zoom Position          | 0xA0  | Address | 0x00  | 0x55  | 0x00            | 0x00           | 0xAF  |
| Query Zoom Position Response | 0xA0  | Address | 0x00  | 0x5D  | Value High Byte | Value Low Byte | 0xAF  |



## Maintenance and Troubleshooting

---

### Maintenance

- Turn the camera off and disconnect the power adapter when not in use for an extended period.
- Use a soft cloth or tissue to clean the camera cover.
- Wipe the camera lens with a soft, dry cloth when cleaning. Gently wipe the lens with a mild detergent if needed. Do not spray the lens directly. Do not use strong or corrosive detergents to avoid scratching the lens and affecting the video quality.

### Troubleshooting

#### **No video output:**

- Check whether the camera power supply is connected, the voltage is normal, and the power indicator is lit.
- If using PoE ensure PoE is enabled on the port and switch has required power available.
- Check whether the camera can perform a self-test after restart.
- Verify that the output cable and display monitor are working properly.

#### **Image cuts out or appears abnormal:**

- Check whether the video output or video display is functioning correctly.

#### **Image distorts while came is moving or appears shaky:**

- Ensure the camera is installed in a solid position.
- Ensure there are no objects near the camera that can be transmitting vibration.

#### **Remote control does not work:**

- Check the remote control batteries.
- Verify the remote control address is set to 1.
- Verify the camera is in normal operating mode.
- Verify camera is not in the on-screen menu as the camera cannot be controlled in this mode.

#### **Serial Port is not working:**

- Verify that the camera serial device protocol, baud rate, and address are all correct.
- Check that the control cable is connected properly.
- Check whether the camera is in normal operating mode.

#### **Cannot connect to the web interface:**

- Check if the camera will output to a screen directly.
- Ensure the network cable is connected properly (green/yellow lights should be visible on the port and flashing indicating network activity)
- Verify you are connected to the same subnet as the camera and are not attempting to use the same IP address.





## Tech Support

---

Have technical questions? We may have answered them already!

Please visit BZBGear's support page ([bzbgear.com/support](http://bzbgear.com/support)) for helpful information and tips regarding our products. Here you will find our Knowledge Base ([bzbgear.com/knowledge-base](http://bzbgear.com/knowledge-base)) with detailed tutorials, quick start guides, and step-by-step troubleshooting instructions. Or explore our YouTube channel, BZB TV ([youtube.com/c/BZBTVchannel](http://youtube.com/c/BZBTVchannel)), for help setting up, configuring, and other helpful how-to videos about our gear.

Need more in-depth support? Connect with one of our technical specialists directly:

**Phone**  
1.888.499.9906

**Email**  
support@bzbgear.com

**Live Chat**  
bzbgear.com



## Warranty

---

BZBGEAR Pro AV products and cameras come with a three-year warranty. An extended two-year warranty is available for our cameras upon registration for a total of five years.

For complete warranty information, please visit [bzbgear.com/warranty](http://bzbgear.com/warranty).

For questions, please call 1.888.499.9906 or email [support@bzbgear.com](mailto:support@bzbgear.com).



## Mission Statement

---

BZBGear is a breakthrough manufacturer of high-quality, innovative audiovisual equipment ranging from AVoIP, professional broadcasting, conferencing, home theater, to live streaming solutions. We pride ourselves on unparalleled customer support and services. Our team offers system design consultation, and highly reviewed technical support for all the products in our catalog. BZBGear delivers quality products designed with users in mind.



## Copyright

---

All the contents in this manual and its copyright are owned by BZBGear. No one is allowed to imitate, copy, or translate this manual without BZBGear's permission. This manual contains no guarantee, standpoint expression or other implies in any form. Product specification and information in this manual is for reference only and subject to change without notice.

**All rights reserved.** No reproducing is allowed without acknowledgement.